

Hydraulic Lever Clamp

Longer Stroke / Block-Fixed

Model GBQ

NEW



Longer stroke allows for variation in die clamping thicknesses.
Fixed with bolts and easy to install on a press without T-slots.

Advantages

Standard Clamp

Requires a spacer at the die clamping site in order to standardize the thickness.

Clamping Thickness : 50mm

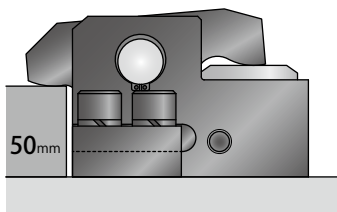

Clamping Thickness : 45mm

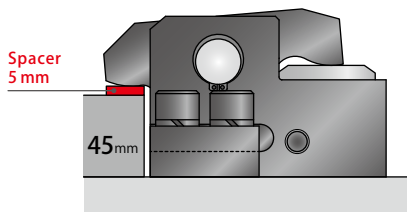

Clamping Thickness : 40mm

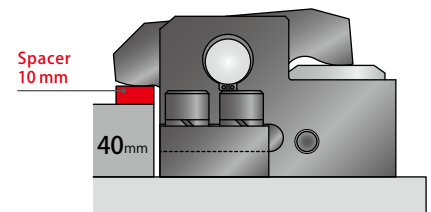

GBQ Clamp

Is able to clamp dies with a thickness variance up to 10 mm. There is no need to install spacers and no accidents caused by incorrect spacer thickness.

Clamping Thickness : 50mm

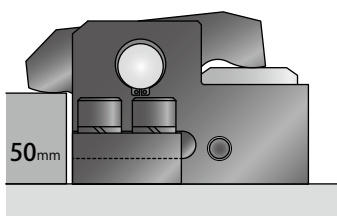

Clamping Thickness : 45mm

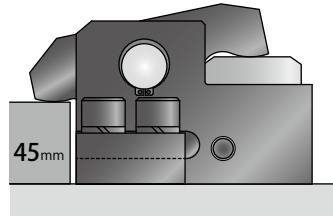

Clamping Thickness : 40mm

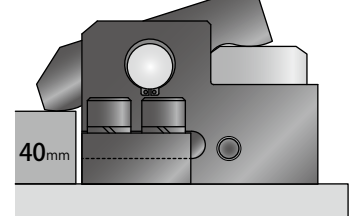

- Notes:
1. We provide GBQ clamp according to the die clamping thickness. Please refer to the external dimensions for detail.
 2. Die clamping thickness varies depending on the clamp size.

System Structure Example

The basic structure with GBQ clamps that do not require T-slot by fixing with bolts. This system is able to control the upper die circuit, lower die circuit, and RA die lifter circuit individually by using a three-circuit hydraulic unit.

Upper Clamp	: GBC Clamp
Lower Clamp	: GBQ Clamp
Loading / Unloading the Die	: MR□ Pre-Roller + RA Die Lifter
Hydraulic Source	: CP□ Unit / CQ□ Unit

We are able to provide different models of clamp for the upper die and lower die.
Please contact us for further information.

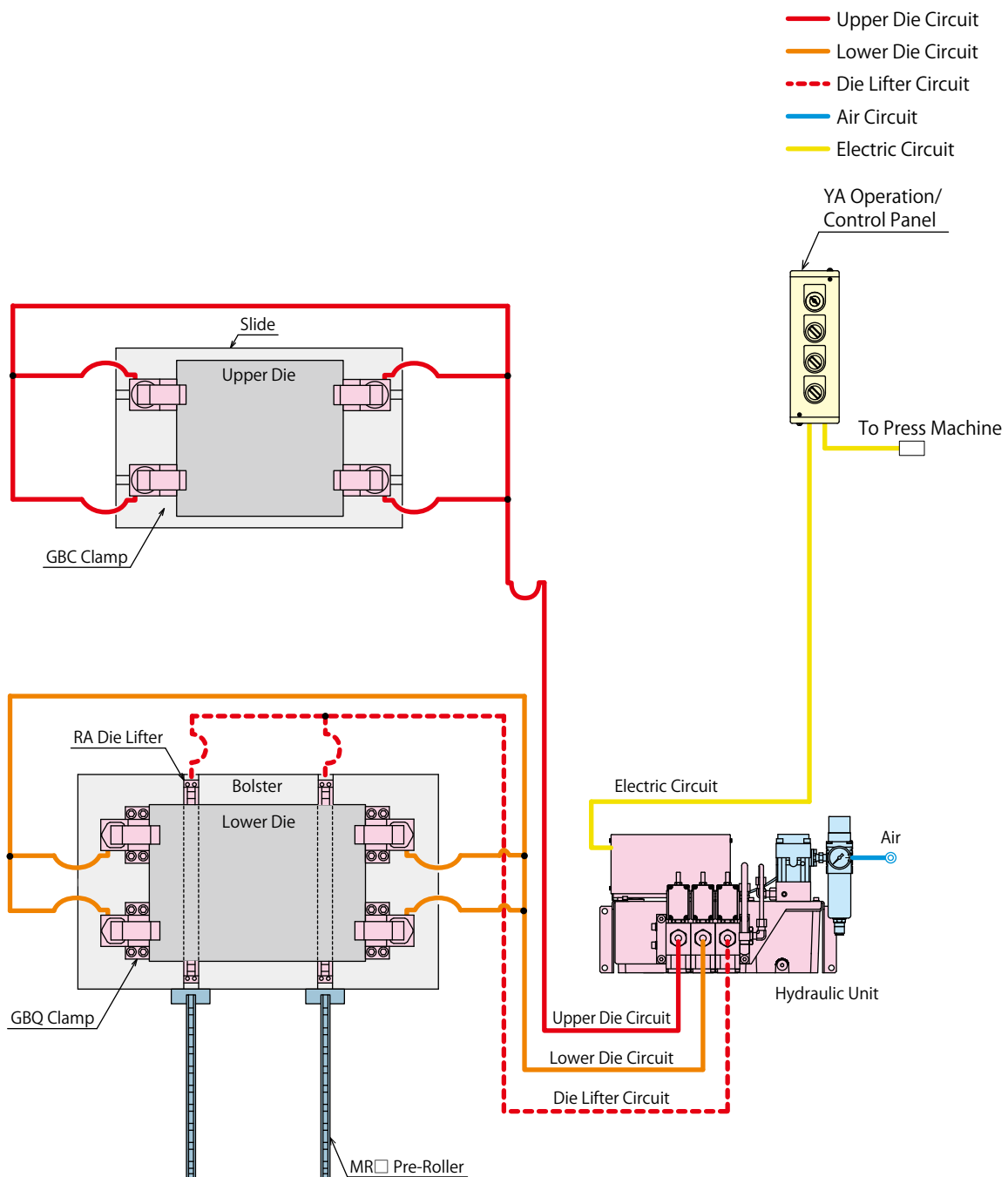

Clamp
Hydraulic Unit
Operation Control Panel

Die Lifter
Pre-Roller

Accessories

Cautions
Company Profile

Clamp

GA
GD
GDB
GBE
GBC
GBF
GBP
GBQ
GN

Hydraulic Unit

CP
CR
CPB
CPD
CPC
CPE
CQC
CQE

Pump Unit

CB
CD
CC

Valve Unit

BC
BH
MV

Operational Control Panel

YP
YA

Model No. Indication

GBQ **040** **0** - **30** - **H**

1 2 3 4

1 Clamping Force

010 : Clamping Force= 10kN	100 : Clamping Force= 100kN
016 : Clamping Force= 16kN	160 : Clamping Force= 160kN
025 : Clamping Force= 25kN	250 : Clamping Force= 250kN
040 : Clamping Force= 40kN	
063 : Clamping Force= 63kN	

2 Design No.

0 : Revision Number

3 Die Clamping Thickness

25 : Die Clamping Thickness h= 25mm
 }
90 : Die Clamping Thickness h= 90mm

Notes:

- ※ The maximum variance of the die clamping thickness.
 (Ex.) When the variance is 30mm~40mm, it is "h=40".
- ※ Selectable **3** Die Clamping Thickness differs according to **1** Clamping Force.
 The Die Clamping Thickness should be between min. h and max. h indicated in the external dimension list.

4 Option ※ Please contact us for specifications / external dimensions.

- Blank** : Standard
- F** : Combined Use with Die Lifter ^{※1}
- G** : Gasket Mounting
- H** : Extra Height Body (When h dimension is more than max. h dimension shown in the external dimension.)
- J** : Low Lever (When h dimension is less than min. h dimension shown in the external dimension.)
- K** : Rear Port
- L□** : Wide Lever (For U-Cut of Die) ^{※2}
- N** : NPT Port ^{※3}
- U□** : With Grease Nipple (GBQ0400 or larger)
- V** : High Temperature (0~120°C) ^{※4}
- X** : With Cover

Notes:

- ※1. The external dimension is the same as standard model, but the ratio of clamp stroke and extra stroke is different. Please refer to page 60 for detail.
 - ※2. Please indicate the U-cut dimension of the die.
 - ※3. Dimensions in the specification sheet and other documents are in inches.
 Only die clamping thickness is indicated by the symbol which is converted into millimeters.
 - ※4. Select the hydraulic unit with pressure relief valve when using under high temperature since there may be pressure fluctuation caused by temperature change.
1. Please contact us for specifications and external dimensions for these options.

Specifications

Model No.		GBQ0100	GBQ0160	GBQ0250	GBQ0400	GBQ0630	GBQ1000	GBQ1600	GBQ2500
Clamping Force	kN	10	16	25	40	63	100	160	250
Working Pressure	MPa	25 (For Rated Clamp Force)							
Withstanding Pressure	MPa	37							
Full Stroke	mm	8	9	10	12	15	15.5	16	16
Clamp Stroke ^{※5}	mm	0.5	1	1.5	3.5	1	1.5	2	2
Extra Stroke ^{※5}	mm	7.5	8	8.5	8.5	14	14	14	14
Applicable Die Clamping Thickness Variation	mm	5	5	5	5	10	10	10	10
Cylinder Capacity (At Full Stroke)	cm ³	4	6	10	19	38	63	105	160
Operating Temperature ^{※6}	°C	0~70 (V: High temperature option is available for 0~120°C)							
Use Frequency ^{※7}		20 Cycles / Day or less							
Pressurizing Agent ^{※8 ※9 ※10}		General Hydraulic Oil Equivalent to ISO-VG-32							

Notes:

- ※5. When using it with Die Lifter, select Option F: Combined Use with Die Lifter.
- ※6. Option V : High Temperature (0~120°C) is for operating in temperatures of 70°C or more.
- ※7. Please contact us for more frequent use.
- ※8. Please contact us for fluids other than those mentioned on the list.
- ※9. If hydraulic viscosity is higher than specified, action time will be longer.
- ※10. If using it at low temperature, action time will be longer because the viscosity of hydraulic oil becomes higher.

Relationship between Option F: Combined Use with Die Lifter and RA Die Lifter

(mm)

Model No.		GBQ0100-F	GBQ0160-F	GBQ0250-F	GBQ0400-F	GBQ0630-F	GBQ1000-F	GBQ1600-F	GBQ2500-F
Full Stroke	mm	8	9	10	12	15	15.5	16	16
Min. Clamp Stroke	mm	3	3	3	4	4	4	4	4
Min. Extra Stroke	mm	2	2	2	3	2	2	2	2
Allowable Die Clamping Thickness Variation	mm	3	4	5	5	9	9.5	10	10
Clearance between GBQ Clamp Lever and RA Die Lifter at Lifted State (A)	RA0180	1.5	1.5	1.5	2.5	2.5	2.5	2.5	2.5
	RA0220	1.5	1.5	1.5	2.5	2.5	2.5	2.5	2.5
	RA0280	1	1	1	2	2	2	2	2
	RA0500	1	1	1	2	2	2	2	2
	RA0800	-	-	-	1	1	1	1	1

RA Die Lifter Lift-Up Stroke

(mm)

Model No.	Lift-Up Stroke
RA0180	1.5
RA0220	1.5
RA0280	2
RA0500	2
RA0800	3

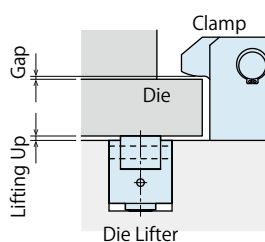
Clamp Hydraulic Unit
 Operation Control Panel

 Die Lifter
 Pre-Roller

Accessories

 Cautions
 Company Profile

Clamp

 GA
 GD
 GBB
 GBE
 GBC
 GBF
 GBP
GBQ
 GN

Hydraulic Unit

 CP
 CR
 CPB
 CPD
 CPC
 CPE
 CQC
 CQE

Pump Unit

 CB
 CD
 CC

Valve Unit

 BC
 BH
 MV

Operational Control Panel

 YP
 YA

External Dimensions

※ This drawing shows standard model.
Contact us for external dimensions for options.

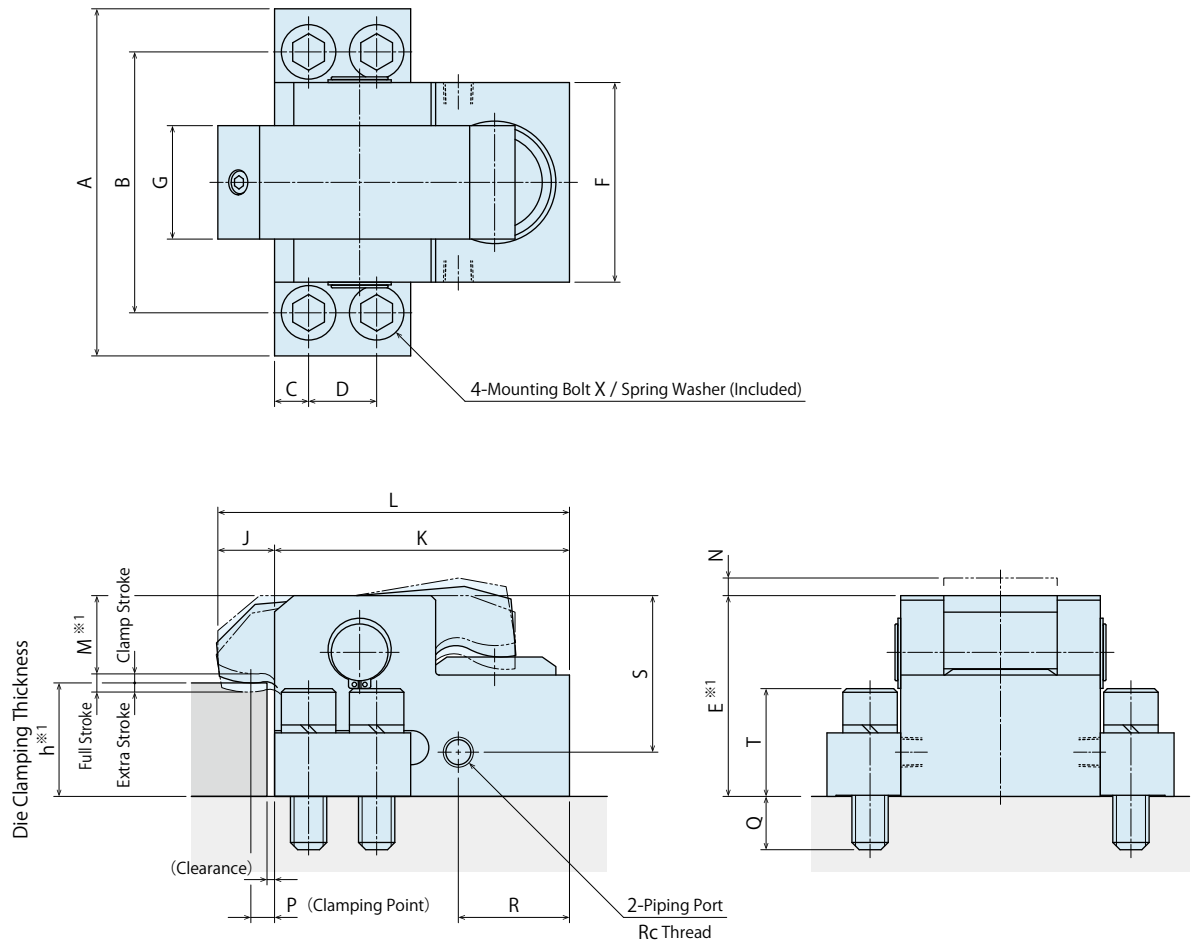

Notes :

1. Do not exceed the clamping force on the specification.
2. Specifications/Contents in this catalog are subject to change without prior notice. Ask for the approval drawing before deciding to purchase.

External Dimensions

(mm)

Model No.	GBQ0100	GBQ0160	GBQ0250	GBQ0400	GBQ0630	GBQ1000	GBQ1600	GBQ2500
Full Stroke	8	9	10	12	15	15.5	16	16
Clamp Stroke ^{※2}	0.5	1	1.5	3.5	1	1.5	2	2
Extra Stroke	7.5	8	8.5	8.5	14	14	14	14
Applicable Die Clamping Thickness Variance	5	5	5	5	10	10	10	10
A	72	90	106	123	153	180	219	270
B	53	66	78	92	115	129	155	199
C	8.5	10	12	13	15	18	22	30
D	15	18	20	26	30	36	46	50
min. E ^{※1}	50.5	57	67	76	93.5	119	137.5	159.5
F	38	48	58	68	88	97	117	144
G	20	26	32	38	50	53	60	73
J	15	17	19	22	25	30	30	30
K	58	70	84	105.5	130	159	199	240
L	73	87	103	127.5	155	189	229	270
max. N	8	9	9.5	11	14.5	15	18	19
p ^{※3}	6	8	8	10	10	10	10	10
Q	12	14.5	20.5	23	23.5	29.5	33	43
R	7	9	10	12	49	68	73	69.5
S	41.5	48	55	59	76.5	102	118.5	137.5
T	26	30.5	36.5	41	47.5	60.5	71	87
X (Nominal x Pitch x Depth) (Designated Maker)	M8 x 1.25 x 30	M10 x 1.5 x 35	M12 x 1.75 x 45	M14 x 2 x 50 (Unbrako)	M16 x 2 x 55 (Unbrako)	M20 x 2.5 x 70 (Unbrako)	M24 x 3 x 80 (Unbrako)	M30 x 3.5 x 100 (Unbrako)
Clearance	1.5	1.5	2	2	2	2	2	2
Rc	Rc1/8	Rc1/8	Rc1/4	Rc1/4	Rc1/4	Rc1/4	Rc1/4	Rc1/4
min. h	25	25	30	30	35	45	45	50
max. h	40	40	50	50	60	70	80	90

Notes :

※1. M dimension (Lever Thickness) in the drawing varies depending on variation in h dimension (Die Clamping Thickness).
Please contact us for further information.

※2. For using GBQ Clamp with Die Lifter, make sure there is a gap between the die and clamp when Die Lifter lifts up.

※3. P dimension (Clamping Point) indicates when h dimension (Die Clamping Thickness) is thick.

1. If you would like to change the ratio of clamp stroke and extra stroke, please contact us.
2. Clamp mounting surface should be smooth without any bumps.

If the clamp mounting surface has bumps or is not smooth, excessive stress will be applied on the clamp lever leading to release error or deformation of the lever and lever pin.

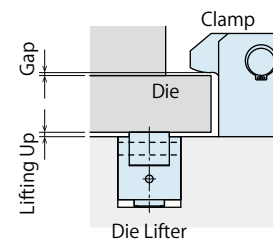

GBQ Clamp The Allowable Protrusion Amount

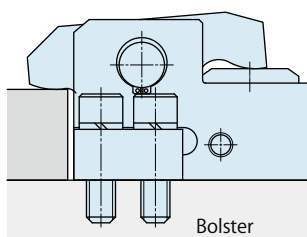

The clamp body should be within the bolster.

Note:

1. The GBQ clamp body should be within the bolster when mounting.

Clamp
Hydraulic Unit
Operation Control Panel

Die Lifter
Pre-Roller

Accessories

Cautions
Company Profile

Clamp

GA

GD

GBB

GBE

GBC

GBF

GBP

GBQ

GN

Hydraulic Unit

CP

CR

CPB

CPD

CPC

CPE

CQC

CQE

Pump Unit

CB

CD

CC

Valve Unit

BC

BH

MV

Operational Control Panel

YP

YA

Cautions

Notes for Design

1) Check Specifications

- Please use each product according to its specifications.
- Operating pressure is 25MPa.
Operating pressure of GN clamp : Hydraulic pressure for lock is 25MPa.
Pneumatic pressure for release is 0.4~0.5MPa.
Do not use clamps with excessive operating pressure.
Falling down of the die due to the damage on clamps leads to injury accident. In order to reduce clamping force, use them with lower operating pressure.

2) Check the Die Clamping Thickness

- Please check the die clamping thickness.
The die clamping thickness of GN clamp should be $h \pm 0.5\text{mm}$.
If using dies other than prescribed, clamps cannot conduct locking action normally and it leads to accident or injury.

3) Clamp surface and T-slot must be parallel to mounting surface of the die.

- If clamp surface is not even or parallel, excessive force is applied to the clamp and it deforms main body and lever of the clamp resulting in accident or injury.

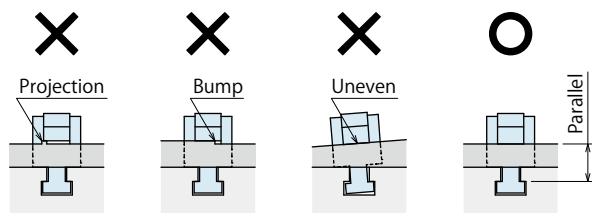

4) Make sure that advance/retraction of the clamp is smoothly conducted. (Model GD / GBE / GBF)

- Please control air cylinder for slide with two-position double solenoid (with detent).
- Supply 0.4MPa or more air pressure to air cylinder.
- Please adjust the moving speed of the clamp with speed controller to be fully stroked within 1 to 2 seconds.
- Do not set the proximity switch to the die surface near the U-cut, since it is used as forward-end detection.
- The clamp sliding surface must be smooth (without any bumps).

5) Make sure that dust, sand, cutting chips or blank pieces do not enter the clamp.

- Clamp does not operate smoothly and may be damaged.

6) When the clamp cylinder sticks out of U-cut or T-slot, please use it within the allowable protrusion amount.

- U-Cut of the Die . . . Model GA / GD
- T-Slot of the Slider / Bolster . . . Model GBB / GBE / GBC / GBF

Model GA / GD

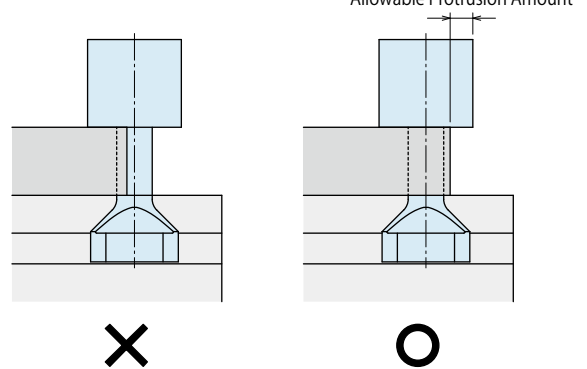

Allowable Protrusion Amount

Model No.	Allowable Protrusion Amount (mm)
GA0100	13
GA0160	14
GA0250 / GD0250	17
GA0400 / GD0400	20
GA0630 / GD0630	26
GA1000 / GD1000	32
GA1600 / GD1600	42
GA2500	50

Model GBB / GBE / GBC / GBF

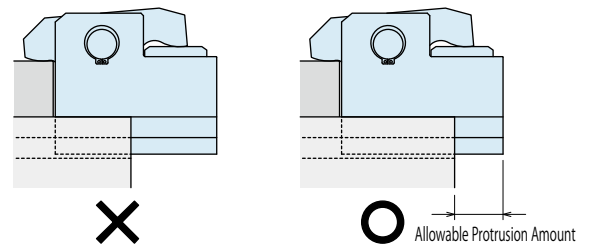

Allowable Protrusion Amount

Model No.	Allowable Protrusion Amount (mm)
GBB0100 / GBE0100	17.5
GBB0160 / GBE0160	21
GBB0250 / GBE0250 / GBC0250 / GBF0250	25
GBB0400 / GBE0400 / GBC0400 / GBF0400	32
GBB0630 / GBE0630 / GBC0630 / GBF0630	39
GBB1000 / GBE1000 / GBC1000 / GBF1000	45
GBB1600 / GBE1600 / GBC1600 / GBF1600	57
GBB2500 / GBE2500 / GBC2500 / GBF2500	69.5
GBB4000 / GBE4000 / GBC4000 / GBF4000	0
GBB5000 / GBE5000 / GBC5000 / GBF5000	0

7) Be careful with mounting position of the clamp. (Model GBP/GBQ only)

- Make sure that main body of the clamp is not out of the mounting surface. Excessive force is applied to the clamp and it deforms the clamp or damages mounting bolt resulting in falling off of the die and accident or injury.

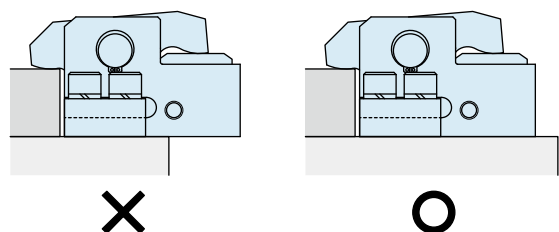

● Installation Notes

1) Check the fluid to use.

- Please use the appropriate fluid by referring to the Hydraulic Fluid List.
- If using hydraulic oil having viscosity higher than viscosity grade ISO-VG-32, action time will be longer.
- If using it at low temperature, action time will be longer because the viscosity of hydraulic oil becomes higher.

2) Procedure before Piping

- The pipeline, piping connector and fixture circuits should be cleaned by thorough flushing. The dust and cutting chips in the circuit may lead to fluid leakage and malfunction. (There is no filter provided with this product for prevention of contaminants in the hydraulic piping or hydraulic system.)

3) Applying Sealing Tape

- Wrap with tape 1 to 2 times following the screwing direction. When piping, be careful that contaminants such as sealing tape do not enter in products. Pieces of the sealing tape can lead to oil leaks and malfunction.

4) Air Bleeding in the Hydraulic Circuit

- If the hydraulic circuit has excessive air, the action time may become very long. If air enters the circuit after connecting the hydraulic port or under the condition of no air in the oil tank, please conduct air bleeding with the end of the piping.

- ① Reduce supply hydraulic pressure to less than 2MPa.
- ② Please loosen the cap nut of pipe fitting that is closest to clamps · RA Die Lifter by one full turn.
- ③ Wiggle the pipeline to loosen the outlet of pipeline fitting. The hydraulic fluid mixed with air comes out.

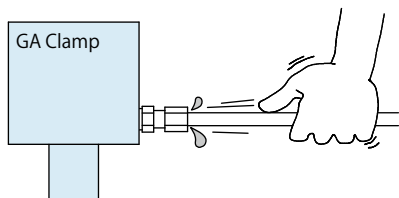

- ④ Tighten the cap nut after bleeding.
- ⑤ It is more effective to bleed air at the highest point inside the circuit or at the end of the circuit.

5) Checking Looseness and Retightening

- At the beginning of the machine installation, the bolt/nut may be tightened lightly. Check torque and re-tighten as required.

6) Mounting the clamp

- After setting the clamp in the T-slot, use attached hex. socket bolts and tighten it with the torque shown below (Model GD / GBE / GBF).

Model No.	Thread Size	Tightening Torque (N·m)
GD0250	M6×1	10
GD0400	M6×1	10
GD0630	M6×1	10
GD1000	M8×1.25	25
GD1600	M8×1.25	25

Model No.	Thread Size	Tightening Torque (N·m)
GBE0250 / GBF0250	M5×0.8	6.3
GBE0400 / GBF0400	M5×0.8	6.3
GBE0630 / GBF0630	M6×1	10
GBE1000 / GBF1000	M8×1.25	25
GBE1600 / GBF1600	M10×1.5	50
GBE2500 / GBF2500	M12×1.75	80
GBE4000 / GBF4000	M16×2	200
GBE5000 / GBF5000	M16×2	200

- Use attached hex. socket bolts and tighten it with the torque shown below (Model GBP / GBQ / GN).

Model No.	Thread Size	Tightening Torque (N·m)
GBP0100 / GBQ0100	M8×1.25	25
GBP0160 / GBQ0160	M10×1.5	50
GBP0250 / GBQ0250	M12×1.75	80
GBP0400 / GBQ0400	M14×2	125
GBP0630 / GBQ0630	M16×2	200
GBP1000 / GBQ1000	M20×2.5	400
GBP1600 / GBQ1600	M24×3	630
GBP2500 / GBQ2500	M30×3.5	1250

Model No.	Thread Size	Tightening Torque (N·m)
GN0251	M6×1	12
GN0401	M8×1.25	30
GN0631	M8×1.25	30
GN1001	M8×1.25	30

7) Wiring of the Forward End Detection Switch

- Make sure there is enough slack in the wire so that the clamp can complete the sliding action without putting tension on the wire.

● Hydraulic Fluid List

Maker	ISO Viscosity Grade ISO-VG-32	
	Anti-Wear Hydraulic Oil	Multi-Purpose Hydraulic Oil
Showa Shell Sekiyu	Tellus S2 M 32	Morlina S2 B 32
Idemitsu Kosan	Daphne Hydraulic Fluid 32	Daphne Super Multi Oil 32
JX Nippon Oil & Energy	Super Hyrando 32	Super Mulpus DX 32
Cosmo Oil	Cosmo Hydro AW32	Cosmo New Mighty Super 32
ExxonMobil	Mobil DTE 24	Mobil DTE 24 Light
Matsumura Oil	Hydol AW-32	
Castrol	Hyspin AWS 32	

Note As it may be difficult to purchase the products as shown in the table from overseas, please contact the respective manufacturer.

Cautions

Notes on Handling

- 1) Shutting down of the machine should be done without load applied to the clamp.
 - This can result in the dropping of a die.
 - When using it with a press machine, make sure to stop the slide at bottom dead point.
- 2) It should be handled by qualified personnel.
 - The hydraulic machine and air compressor should be handled and maintained by qualified personnel.
- 3) Do not handle or remove the machine unless the safety protocols are ensured.
 - ① The machine and equipment can only be inspected or prepared when it is confirmed that the preventive devices are in place.
 - ② Before the machine is removed, make sure that the above-mentioned safety measures are in place. Shut off the air of hydraulic source and make sure no pressure exists in the hydraulic circuit.
 - ③ After stopping the machine, do not remove until the temperature cools down.
 - ④ Make sure there is no abnormality in the bolts and respective parts before restarting the machine or equipment.
- 4) Do not touch clamps while they are working.
 - Otherwise, your hands may be injured.

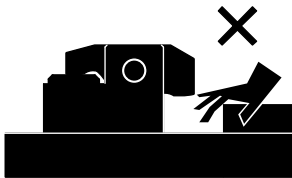

- 5) When changing the width of the die, make sure to check the allowable protrusion amount.
 - If using it with beyond allowable protrusion amount, excessive force is applied to the clamp which deforms or damages the clamp resulting in falling off of the die and accident or injury. Please refer to "Notes for Design (6)" on P.067 for the allowable protrusion amount.
- 6) Please hold the main body of the clamp when moving or removing it.
 - If pulling on hydraulic hose or air tube, the clamp will fall off leading to accident or injury. Also, rivet part of the hose will be loosened leading to fluid leakage.

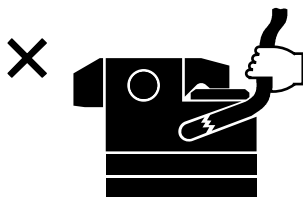

- 7) Do not disassemble or modify it.
 - If the equipment is taken apart or modified, the warranty will be void even within the warranty period.
- 8) Please do not pour water / oil over the product.
 - It may lead to malfunction or deterioration of the product and cause an accident.



Clamp
Hydraulic Unit
Operation Control Panel

Die Lifter
Pre-Roller

Accessories

Cautions
Company Profile

Clamp

GA

GD

GBB

GBE

GBC

GBF

GBP

GBQ

GN

Hydraulic Unit

CP

CR

CPB

CPD

CPC

CPE

CQC

CQE

Pump Unit

CB

CD

CC

Valve Unit

BC

BH

MV

Operational Control Panel

YP

YA

● Cautions

● Installation Notes (Cautions for Hydraulic Series)

- 1) Check the fluid to use
 - Please use the appropriate fluid by referring to the Hydraulic Fluid List.
 - If hydraulic oil with viscosity grade higher than ISO-VG-32 is used, action time would be longer.
 - If using it at low temperature, action time will be longer because the viscosity of hydraulic oil becomes higher.
- 2) Procedure before Piping
 - The pipeline, piping connector and fixture circuits should be cleaned by thorough flushing.
 - The dust and cutting chips in the circuit may lead to fluid leakage and malfunction.
 - Our products except some valves are not equipped with protective function to prevent dust and cutting chips going into the hydraulic system and pipeline.
- 3) Applying Sealing Tape
 - Wrap with tape 1 to 2 times following the screwing direction.
 - Pieces of the sealing tape can lead to air leaks and malfunction.
 - In order to prevent a foreign substance from going into the product during piping, it should be carefully cleaned.
- 4) Air Bleeding in the Hydraulic Circuit
 - If the hydraulic circuit has excessive air, the action time may become very long.
After installing the hydraulic circuit, or if the pump run out of oil, be sure to bleed air by the following step.
 - ① Reduce hydraulic supply pressure to less than 2MPa.
 - ② Please loosen the cap nut of pipe fitting that is closest to clamps · RA die lifters by one full turn.
 - ③ Wiggle the pipeline to loosen the outlet of pipeline fitting.
The hydraulic fluid mixed with air comes out.

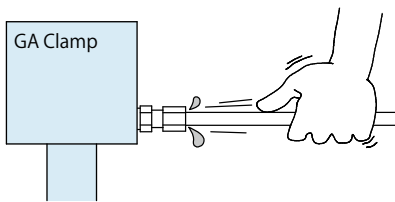

- ④ Tighten the cap nut after bleeding.
 - ⑤ It is more effective to bleed air at the highest point inside the circuit or at the end of the circuit.
- 5) Checking Looseness and Retightening
 - At the beginning of the machine installation, the bolt/nut may be tightened lightly.
Check torque and re-tighten as required.

● Hydraulic Fluid List

Maker	ISO Viscosity Grade ISO-VG-32	
	Anti-Wear Hydraulic Oil	Multi-Purpose Hydraulic Oil
Showa Shell Sekiyu	Tellus S2 M 32	Morlina S2 B 32
Idemitsu Kosan	Daphne Hydraulic Fluid 32	Daphne Super Multi Oil 32
JX Nippon Oil & Energy	Super Hyrando 32	Super Mulpus DX 32
Cosmo Oil	Cosmo Hydro AW32	Cosmo New Mighty Super 32
ExxonMobil	Mobil DTE 24	Mobil DTE 24 Light
Matsumura Oil	Hydol AW-32	
Castrol	Hyspin AWS 32	

Note : As it may be difficult to purchase the products as shown in the table from overseas, please contact the respective manufacturer.

● Notes on Hydraulic Cylinder Speed Control Unit



Please pay attention to the cautions below. Design the hydraulic circuit for controlling the action speed of hydraulic cylinder. Improper circuit design may lead to malfunctions and damages. Please review the circuit design in advance.

● Flow Control Circuit for Single Acting Cylinder

For spring return single acting cylinders, restricting flow during release can extremely slow down or disrupt release action. The preferred method is to control the flow during the lock action using a valve that has free-flow in the release direction. It is also preferred to provide a flow control valve at each actuator.

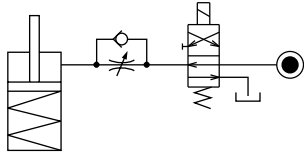

Accelerated clamping speed by excessive hydraulic flow to the cylinder may sustain damage. In this case add flow control to regulate flow.

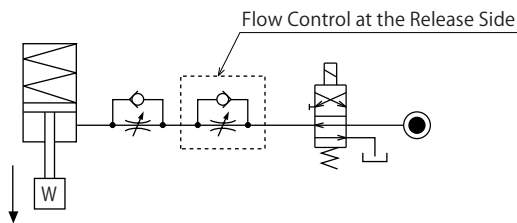

● Flow Control Circuit for Double Acting Cylinder

Flow control circuit for double acting cylinder should have meter-out circuits for both the lock and release sides. Meter-in control can have adverse effect by presence of air in the system.

【Meter-out Circuit】

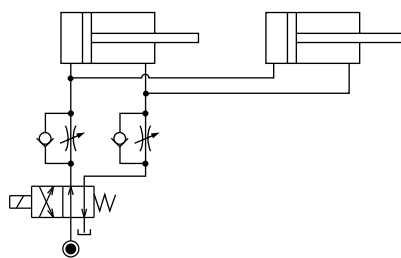

【Meter-in Circuit】

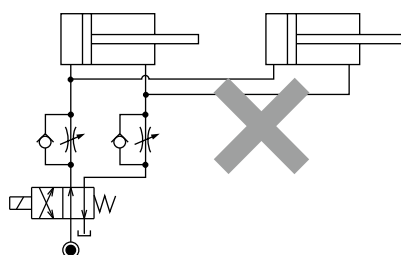

In the case of meter-out circuit, the hydraulic circuit should be designed with the following points.

- ① Single acting components should not be used in the same flow control circuit as the double acting components. The release action of the single acting cylinders may become erratic or very slow.

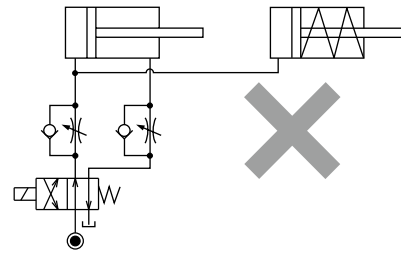

Refer to the following circuit when both the single acting cylinder and double acting cylinder are used together.

- Separate the control circuit.

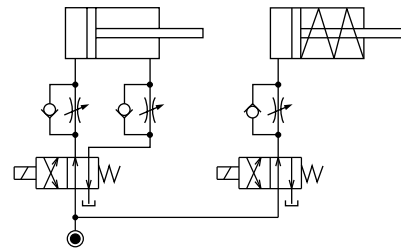

- Reduce the influence of double acting cylinder control unit. However, due to the back pressure in tank line, single action cylinder is activated after double action cylinder works.

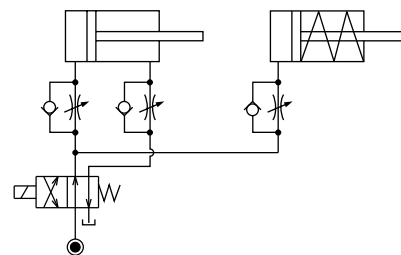

- ② In the case of meter-out circuit, the inner circuit pressure may increase during the cylinder action because of the fluid supply. The increase of the inner circuit pressure can be prevented by reducing the supplied fluid beforehand via the flow control valve. Especially when using sequence valve or pressure switches for clamping detection. If the back pressure is more than the set pressure then the system will not work as it is designed to.

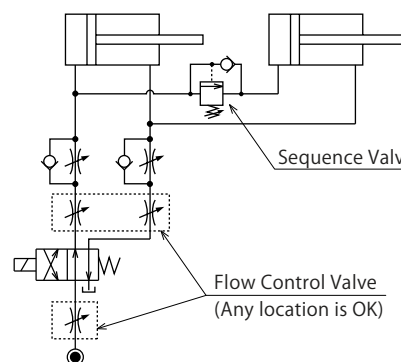

● Cautions

● Notes on Handling

- 1) It should be handled by qualified personnel.
 - The hydraulic machine / air compressor should be handled and maintained by qualified personnel.
- 2) Do not handle or remove the machine unless the safety protocols are ensured.
 - ① The machine and equipment can only be inspected or prepared when it is confirmed that the preventive devices are in place.
 - ② Before the machine is removed, make sure that the above-mentioned safety measures are in place. Shut off the air of hydraulic source and make sure no pressure exists in the hydraulic and air circuit.
 - ③ After stopping the machine, do not remove until the temperature cools down.
 - ④ Make sure there is no abnormality in the bolts and respective parts before restarting the machine or equipment.
- 3) Do not touch clamps (cylinders) while they are working. Otherwise, your hands may be injured.

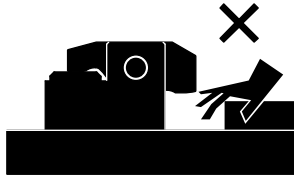

- 4) Do not disassemble or modify.
 - If the equipment is taken apart or modified, the warranty will be voided even within the warranty period.

● Maintenance • Inspection

- 1) Removal of the Machine and Shut-off of Pressure Source
 - Before the machine is removed, make sure that the above-mentioned safety measures are in place. Shut off the air of hydraulic source and make sure no pressure exists in the hydraulic and air circuit.
 - Make sure there is no abnormality in the bolts and respective parts before restarting.
- 2) Regularly clean the area around the equipment.
 - If it is used when the surface is contaminated with dirt, it may lead to packing seal damage, malfunctioning, fluid leakage and air leaks.

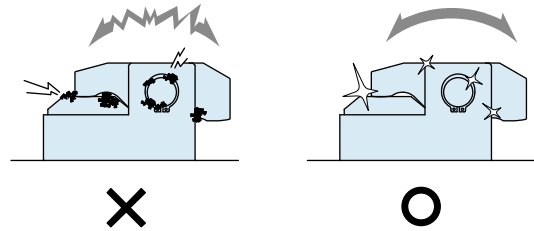

- 3) If disconnecting by couplers on a regular basis, air bleeding should be carried out daily to avoid air mixed in the circuit.
- 4) Regularly tighten bolts and pipe line, mounting bolts, nuts, circlips and cylinders to ensure proper use.
- 5) Make sure the hydraulic fluid has not deteriorated.
- 6) Make sure there is smooth action and no abnormal noise.
 - Especially when it is restarted after left unused for a long period, make sure it can be operated correctly.
- 7) The products should be stored in the cool and dark place without direct sunshine or moisture.
- 8) Please contact us for overhaul and repair.

● Warranty

1) Warranty Period

- The product warranty period is 18 months from shipment from our factory or 12 months from initial use, whichever is earlier.

2) Warranty Scope

- If the product is damaged or malfunctions during the warranty period due to faulty design, materials or workmanship, we will replace or repair the defective part at our expense. Defects or failures caused by the following are not covered.

- ① If the stipulated maintenance and inspection are not carried out.
- ② If the product is used while it is not suitable for use based on the operator' s judgment, resulting in defect.
- ③ If it is used or handled in inappropriate way by the operator. (Including damage caused by the misconduct of the third party.)
- ④ If the defect is caused by reasons other than our responsibility.
- ⑤ If repair or modifications are carried out by anyone other than Kosmek, or without our approval and confirmation, it will void warranty.
- ⑥ Other caused by natural disasters or calamities not attributable to our company.
- ⑦ Parts or replacement expenses due to parts consumption and deterioration. (Such as rubber, plastic, seal material and some electric components.)

Damages excluding from direct result of a product defect shall be excluded from the warranty.

Clamp
Hydraulic Unit
Operation Control Panel

Die Lifter
Pre-Roller

Accessories

Cautions
Company Profile

Cautions

Installation Notes
(For Hydraulic Series)

Hydraulic Fluid List

Notes on Hydraulic Cylinder
Speed Control Unit

Notes on Handling

Maintenance / Inspection

Warranty

Company Profile

Company Profile

Our Products

History

Sales Office

Sales Offices

Sales Offices across the World

Japan	TEL. +81-78-991-5162	FAX. +81-78-991-8787
Overseas Sales	KOSMEK LTD. 1-5, 2-chome, Murotani, Nishi-ku, Kobe-city, Hyogo, Japan 651-2241 〒651-2241 兵庫県神戸市西区室谷2丁目1番5号	
USA	TEL. +1-630-620-7650	FAX. +1-630-620-9015
KOSMEK (USA) LTD.	650 Springer Drive, Lombard, IL 60148 USA	
Mexico	TEL. +52-442-161-2347	
KOSMEK USA Mexico Office	Blvd Jurica la Campana 1040, B Colonia Punta Juriquilla Queretaro, QRO 76230 Mexico	
EUROPE	TEL. +43-463-287587	FAX. +43-463-287587-20
KOSMEK EUROPE GmbH	Schleppeplatz 2 9020 Klagenfurt am Wörthersee Austria	
China	TEL. +86-21-54253000	FAX. +86-21-54253709
KOSMEK (CHINA) LTD. 考世美(上海)貿易有限公司	Room601, RIVERSIDE PYRAMID No.55, Lane21, Pusan Rd, Pudong Shanghai 200125, China 中国上海市浦东新区浦三路21弄55号银亿滨江中心601室 200125	
India	TEL. +91-9880561695	
KOSMEK LTD - INDIA	F 203, Level-2, First Floor, Prestige Center Point, Cunningham Road, Bangalore -560052 India	
Thailand	TEL. +66-2-300-5132	FAX. +66-2-300-5133
Thailand Representative Office	67 Soi 58, RAMA 9 Rd., Suanluang, Suanluang, Bangkok 10250, Thailand	
Taiwan (Taiwan Exclusive Distributor)	TEL. +886-2-82261860	FAX. +886-2-82261890
Full Life Trading Co., Ltd. 盈生貿易有限公司	16F-4, No.2, Jian Ba Rd., Zhonghe District, New Taipei City Taiwan 23511 台湾新北市中和區建八路2號 16F-4 (遠東世紀廣場)	
Philippines (Philippines Exclusive Distributor)	TEL. +63-2-310-7286	FAX. +63-2-310-7286
G.E.T. Inc, Phil.	Victoria Wave Special Economic Zone Mt. Apo Building, Brgy. 186, North Caloocan City, Metro Manila, Philippines 1427	
Indonesia (Indonesia Exclusive Distributor)	TEL. +62-21-29628607	FAX. +62-21-29628608
PT. Yamata Machinery	Delta Commercial Park I, Jl. Kenari Raya B-08, Desa Jayamukti, Kec. Cikarang Pusat Kab. Bekasi 17530 Indonesia	

Sales Offices in Japan

Head Office	TEL. 078-991-5162	FAX. 078-991-8787
Osaka Sales Office	〒651-2241 兵庫県神戸市西区室谷2丁目1番5号	
Overseas Sales		
Tokyo Sales Office	TEL. 048-652-8839	FAX. 048-652-8828
	〒331-0815 埼玉県さいたま市北区大成町4丁目81番地	
Nagoya Sales Office	TEL. 0566-74-8778	FAX. 0566-74-8808
	〒446-0076 愛知県安城市美園町2丁目10番地1	
Fukuoka Sales Office	TEL. 092-433-0424	FAX. 092-433-0426
	〒812-0006 福岡県福岡市博多区上牟田1丁目8-10-101	

Global Network

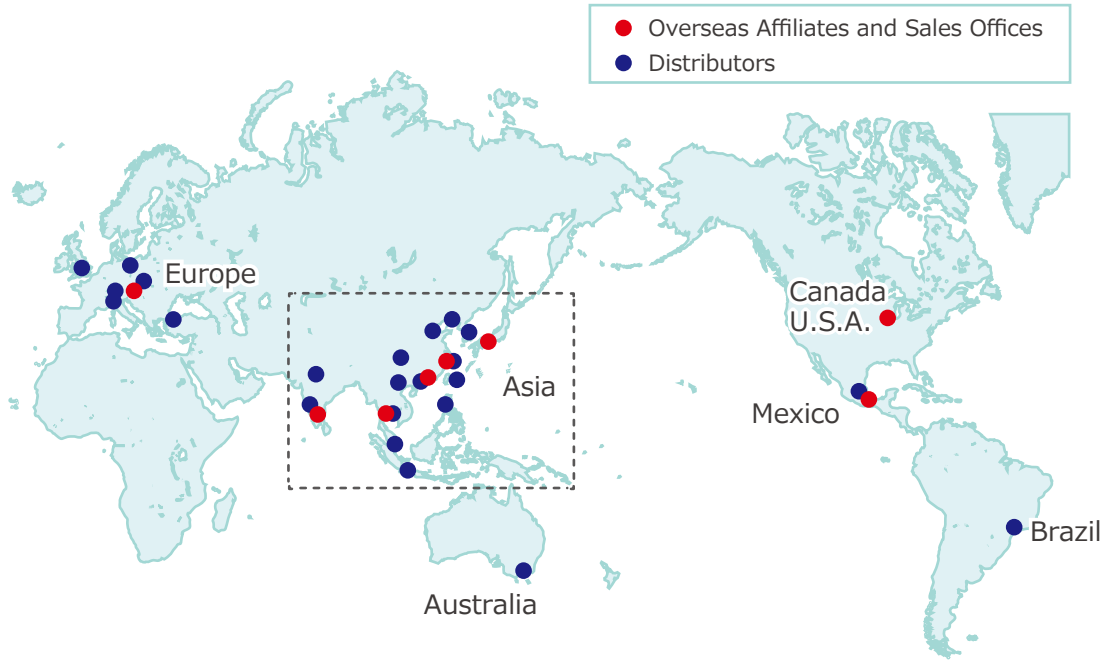

Asia Detailed Map



KOSMEK
Harmony in Innovation

● FOR FURTHER INFORMATION ON UNLISTED SPECIFICATIONS AND SIZES, PLEASE CALL US.
● SPECIFICATIONS IN THIS CATALOG ARE SUBJECT TO CHANGE WITHOUT NOTICE.

