

2.5 – 7MPa

Double Acting

New

Hydraulic Double Acting Work Support

Shorter Cycle Time • Back Pressure Resistant



Model LDD

Hydraulic Double Acting Work Support

Model LDD



Shorter Cycle Time • Back Pressure Resistant

Double Acting Work Support for Low Pressure

Features of Double Acting Work Support

- **Secure Release Action**

The work support is not affected by back pressure, and releases forcibly with a hydraulic pressure.

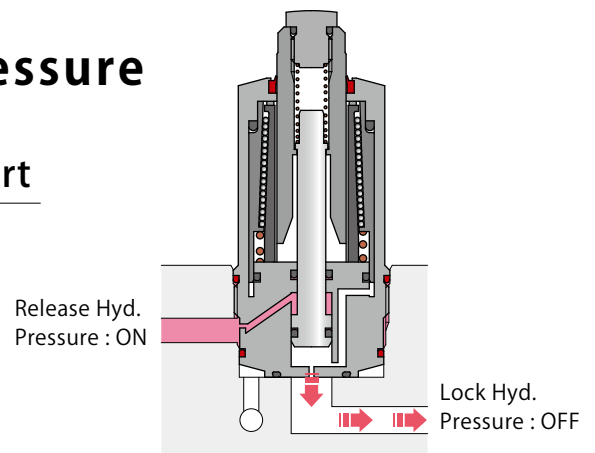

- **Compact Body**

Compact as our conventional single acting work support.

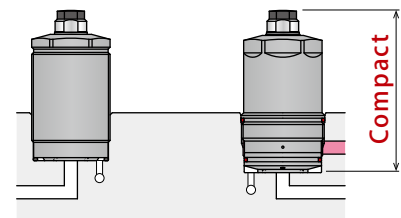

LD Single Acting Model LDD Double Acting Model

- **Long Stroke Model Available**

Offering the standard stroke model and the long stroke model.

- **Standard Stroke Model**

Model No.	LDD0300-□	LDD0360-□	LDD0450-□	
Plunger Stroke	mm	8	8	10

- **Long Stroke Model**

Model No.	LDD0300-Q	LDD0360-Q	LDD0450-Q	
Plunger Stroke	mm	16	16	20

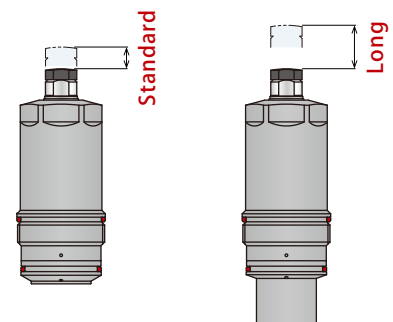

Standard Stroke Model Long Stroke Model

Advantages of Double Acting Work Support

• Cycle Time Reduction

Faster and more secure movement is required for an automated production line. Single action release movement becomes unstable and longer when back pressure is generated from other double acting cylinders during unclamping. Using the double acting model enables stable release and its action confirmation with a hydraulic pressure switch for the fastest cycle time.

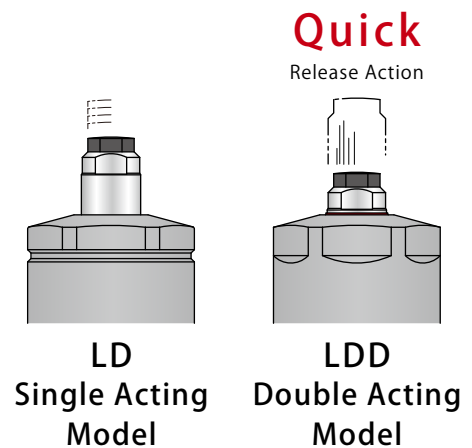

• Steady Automation

Secure action confirmation is difficult with the single acting model, because it is released by spring. On the other hand, the double acting model enables action confirmation by using a hydraulic pressure switch. This allows more reliable automation such as an operation with a workpiece transfer robot.

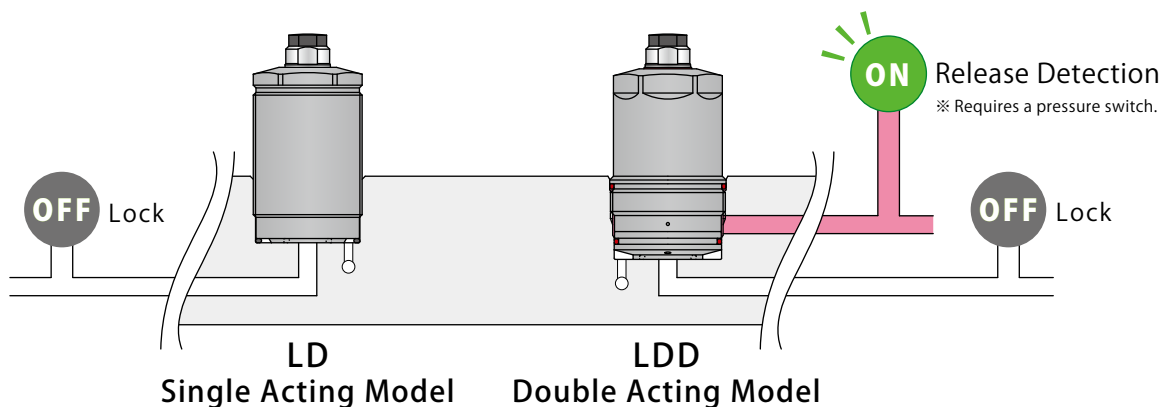

• Simple Fixture Design

Release hydraulic pressure can be supplied from the side surface of the body. Simple fixture design is possible as pressure can be supplied from any direction.

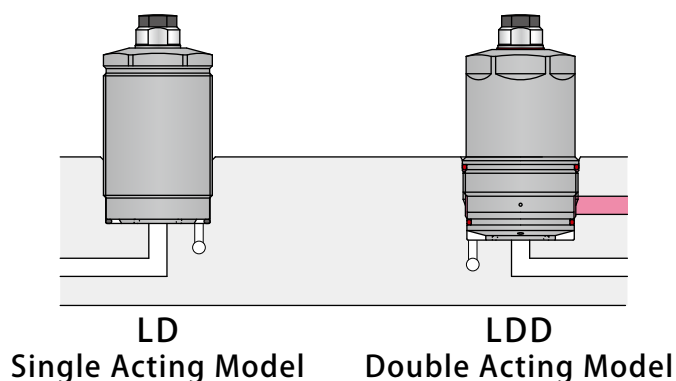

● Cross Section

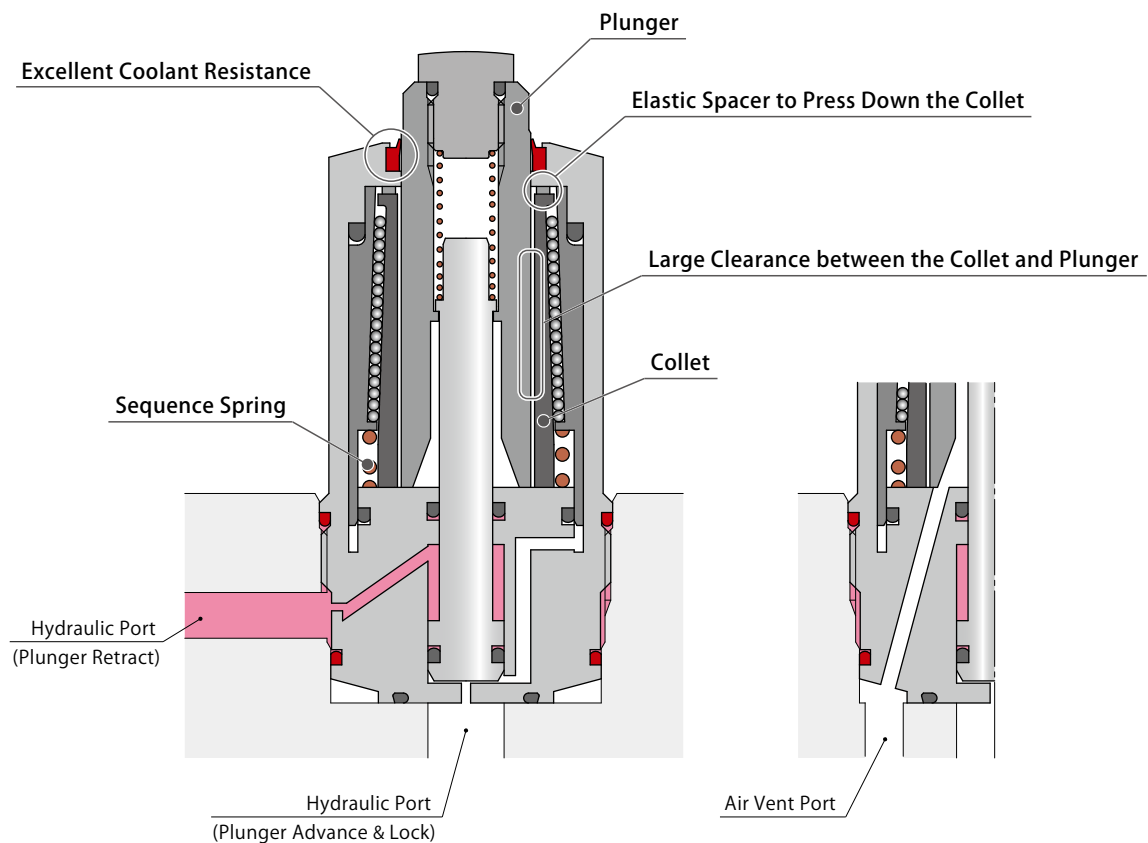

- **It adopts the collet structure, the first in the world, ensuring powerful support and smooth action.**

KOSMEK was the first to develop the collet design in 1996.

Compared with the traditional sleeve design, it ensures powerful gripping force via a wedge effect.

In addition, a larger gap between collet and plunger is designed to prevent sticking and allow smoother action.

- **Concrete Workpiece Touch**

As the collet gripping the plunger is always pressed downwards, it helps prevent tilting when locked and the clearance with the workpiece.

- **Certain Sequence Action**

As it is equipped with a powerful sequencing spring, the action sequences as such;

Plunger goes up → workpiece touches → collet locks. This is carried out via one hydraulic circuit system.

- **Excellent Coolant Resistance**

Our exclusive dust seal is designed to protect against high pressure coolant. It also has high durability against chlorine-based coolant by using a sealing material with excellent chemical resistance.

- **Air Purging Possible**

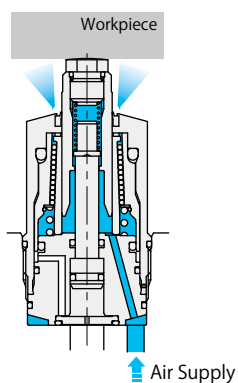

● Action Description

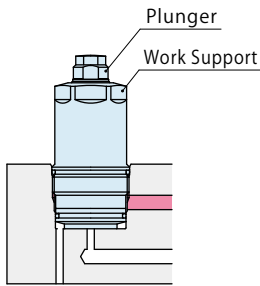

Release Hyd. Pressure : ON
Lock Hyd. Pressure : OFF
The state of plunger down.

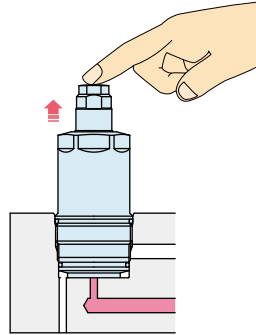

Release Hyd. Pressure : OFF
Lock Hyd. Pressure : ON
Plunger rises with lock pressure
and stops after touching workpiece.

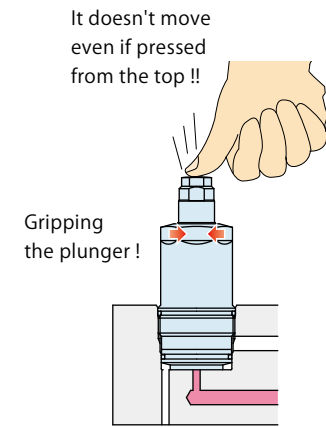

Release Hyd. Pressure : OFF
Lock Hyd. Pressure : ON
Once it is in the stopped position
where it touches the workpiece,
the plunger doesn't go down
even if pressed from above.

● Internal Action Description

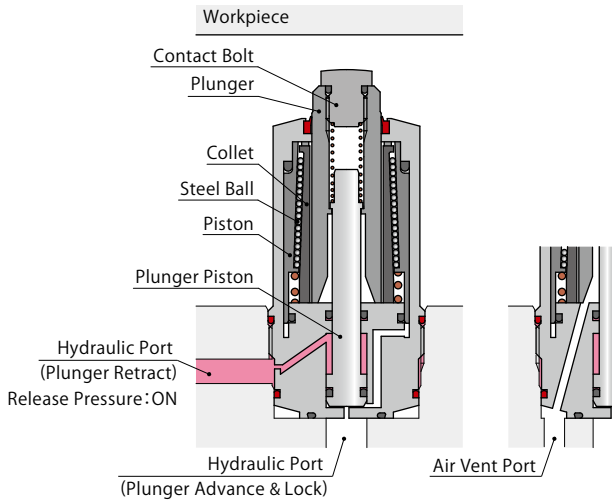

At Released

Plunger is lowered by release pressure.

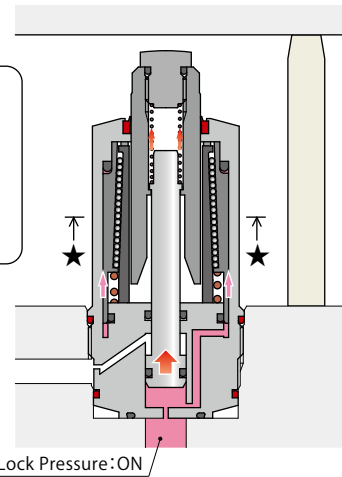
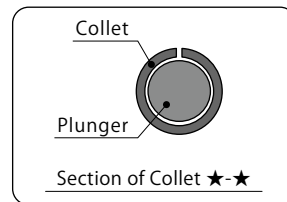

Plunger extends

Plunger piston is extended by releasing release pressure
and supplying lock pressure. Plunger rises via spring force
to the workpiece with this action.

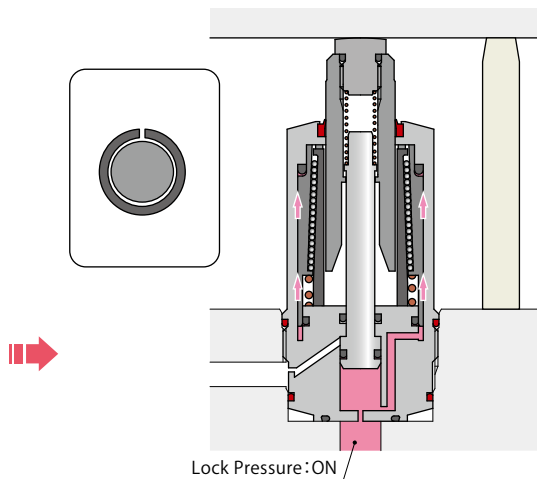

Contact bolt makes contact with workpiece

Plunger piston rises to the upper limit even after
contact bolt makes contact with workpiece.

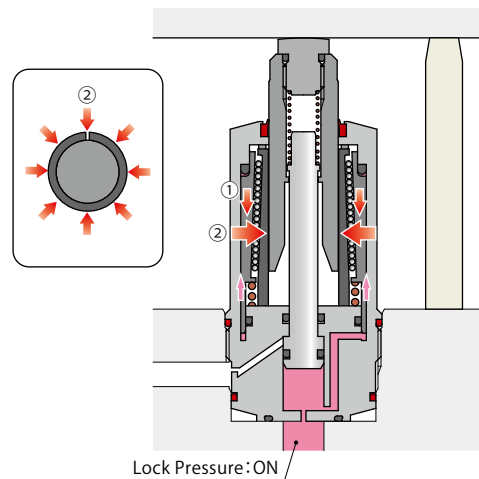

Locked State

- ① The piston starts to press down via hydraulic pressure.
- ② The tapering action between the piston and collet affects the steel ball so that the collet can grip the plunger with even and strong power to generate the supporting force.

Model No. Indication

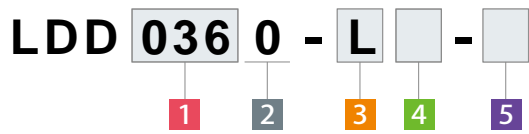

1 Body Size

030 : $\phi C=30\text{mm}$, External Thread M32×1.5

036 : $\phi C=36\text{mm}$, External Thread M38×1.5

045 : $\phi C=45\text{mm}$, External Thread M48×1.5

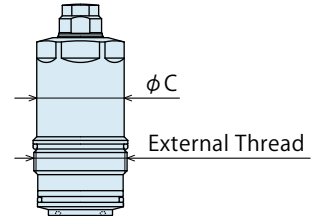

2 Design No.

0 : Revision Number

3 Plunger Spring Force

L : Low Spring Force

H : High Spring Force

Blank : When selecting **5** Option **Q**

4 Plunger Action Confirmation

Blank : No Action Confirmation (Standard)

M : Air Sensing Option

5 Option

Blank : Hydraulic Advance Model (Standard)

Q : Hydraulic Advance Long Stroke Model

Specifications

Option 5 Blank

Model No.		LDD0300-□ LDD0300-□M	LDD0360-□ LDD0360-□M	LDD0450-□ LDD0450-□M
Support Force at 7MPa	kN	4.0	5.5	10.0
Support Force (Calculation Formula) ^{※1}	kN	$0.70 \times P - 0.91$	$0.96 \times P - 1.25$	$1.75 \times P - 2.28$
Plunger Stroke	mm	8	8	10
		(Effective Stroke ^{※3} 7.5)	(Effective Stroke ^{※3} 7.5)	(Effective Stroke ^{※3} 9.5)
Cylinder	Advance&Lock	0.9	1.3	2.0
	Capacity cm ³ Retract	0.2	0.3	0.4
Plunger ^{※2}	L : Low Spring	3.6 ~ 5.7	4.7 ~ 7.8	5.8 ~ 9.7
	H : High Spring	4.9 ~ 8.0	6.2 ~ 11.0	7.9 ~ 13.6
Spring Force	N			
Max. Operating Pressure	MPa	7.0		
Min. Operating Pressure	MPa	2.5		
Withstanding Pressure	MPa	10.5		
Operating Temperature	°C	0 ~ 70		
Usable Fluid		General Hydraulic Oil equivalent to ISO-VG-32		
Weight	kg	0.30	0.30	0.85

Option 5 Q

Model No.		LDD0300-Q LDD0300-M-Q	LDD0360-Q LDD0360-M-Q	LDD0450-Q LDD0450-M-Q
Support Force at 7MPa	kN	4.0	5.5	10.0
Support Force (Calculation Formula) ^{※1}	kN	$0.70 \times P - 0.91$	$0.96 \times P - 1.25$	$1.75 \times P - 2.28$
Plunger Stroke	mm	16	16	20
		(Effective Stroke ^{※3} 15.5)	(Effective Stroke ^{※3} 15.5)	(Effective Stroke ^{※3} 19.5)
Cylinder	Advance&Lock	1.3	1.9	2.8
	Capacity cm ³ Retract	0.4	0.6	0.8
Plunger Spring Force ^{※2}	N	4.9 ~ 11.4	6.2 ~ 12.9	7.8 ~ 20.4
Max. Operating Pressure	MPa	7.0		
Min. Operating Pressure	MPa	2.5		
Withstanding Pressure	MPa	10.5		
Operating Temperature	°C	0 ~ 70		
Usable Fluid		General Hydraulic Oil equivalent to ISO-VG-32		
Weight	kg	0.35	0.35	0.90

Notes : ※1. P in the formula for support force indicates the hydraulic pressure (MPa).

※2. The plunger spring force indicates the spring design value. It may vary depending on sliding resistance of the plunger and characteristic of the spring, etc. Please read it as a reference value of workpiece contact force. Regarding to workpiece contacting force for 4 M : Air Sensing option, please refer to P.19.

※3. Please use the work support within the effective stroke range.

When the work support touches a workpiece within 0.5mm stroke from the plunger retract-end, a force which is larger than the plunger spring force will be applied to the workpiece.

● Performance Curve (LDD-□ : Hydraulic Advance Model)

Applicable Model

LDD **036** **0** - **LH** - **Blank**

1 Body Size

5 Option : Blank

■ Support Force Graph ※ This graph shows the support force under static load condition.

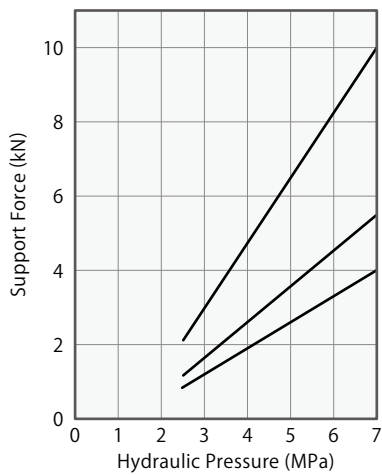

Model No.	Support Force (kN)		
	LDD0300-□	LDD0360-□	LDD0450-□
7	4.0	5.5	10.0
6.5	3.6	5.0	9.1
6	3.3	4.5	8.2
5.5	2.9	4.0	7.3
5	2.6	3.6	6.5
4.5	2.2	3.1	5.6
4	1.9	2.6	4.7
3.5	1.5	2.1	3.8
3	1.2	1.6	3.0
2.5	0.8	1.2	2.1
Support Force Formula ※1 kN	$0.70 \times P - 0.91$	$0.96 \times P - 1.25$	$1.75 \times P - 2.28$

Note : ※ 1. P : Operating Hydraulic Pressure (MPa)

■ Load / Displacement Graph ※ This graph shows the static load displacement at 7 MPa hydraulic pressure.

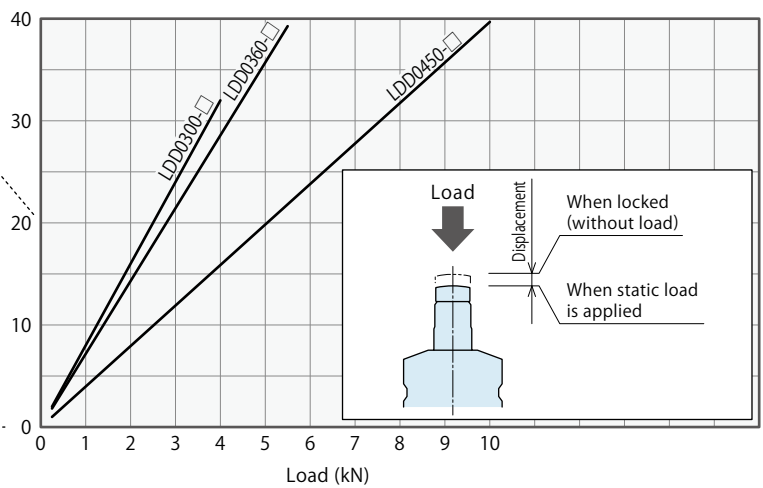
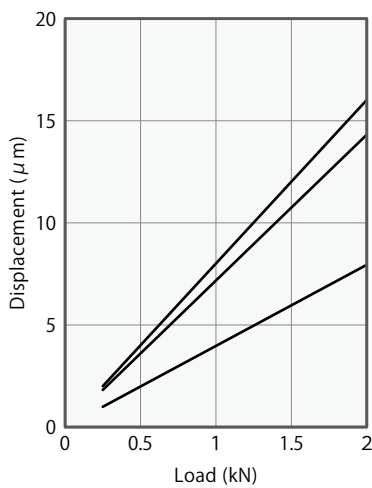

Performance Curve (LDD-Q : Hydraulic Advance Long Stroke Model)

Applicable Model

LDD 036 0 - Q

1 Body Size 5 Option : Q

Support Force Graph ※ This graph shows the support force under static load condition.

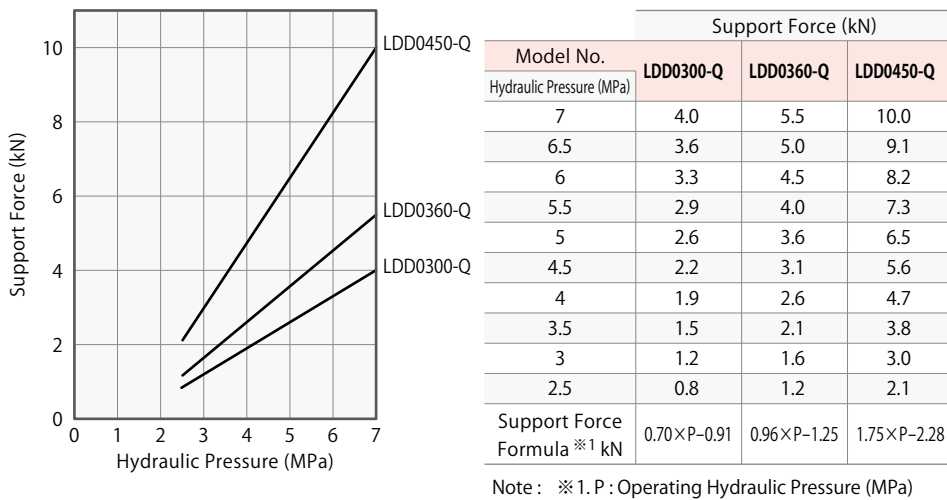

Load / Displacement Graph ※ This graph shows the static load displacement at 7 MPa hydraulic pressure.

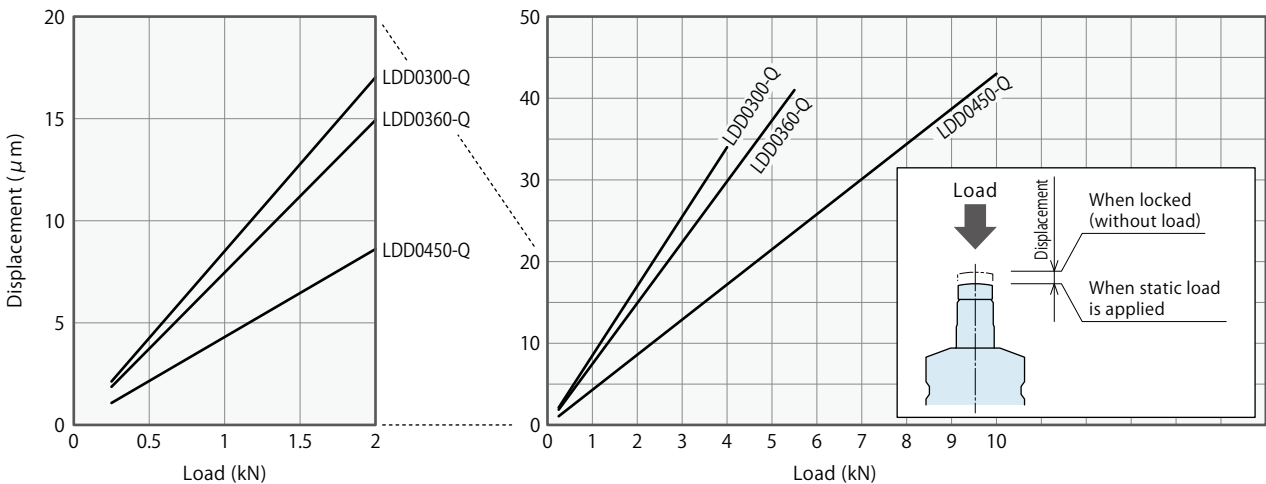

※ The displacement of LDD-Q : Long Stoke Model is larger than that of LDD : Standard Model.

Performance Curve (LDD-□M : Hydraulic Advance Air Sensing Option)

Applicable Model

LDD 036 0 - L H M - Blank

1 Body Size

5 Option : Blank

4 Plunger Action Confirmation : M

Support Force Graph ※ This graph shows the support force under static load condition.

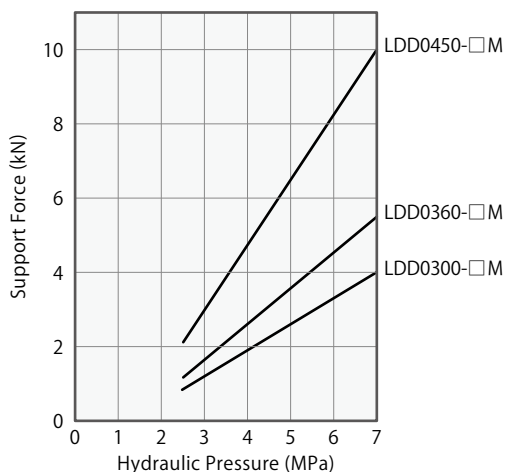

Model No. Hydraulic Pressure (MPa)	Support Force (kN)		
	LDD0300-□M	LDD0360-□M	LDD0450-□M
7	4.0	5.5	10.0
6.5	3.6	5.0	9.1
6	3.3	4.5	8.2
5.5	2.9	4.0	7.3
5	2.6	3.6	6.5
4.5	2.2	3.1	5.6
4	1.9	2.6	4.7
3.5	1.5	2.1	3.8
3	1.2	1.6	3.0
2.5	0.8	1.2	2.1
Support Force Formula ※1 kN	$0.70 \times P - 0.91$	$0.96 \times P - 1.25$	$1.75 \times P - 2.28$

Note : ※1. P : Operating Hydraulic Pressure (MPa)

Load / Displacement Graph ※ This graph shows the static load displacement at 7 MPa hydraulic pressure.

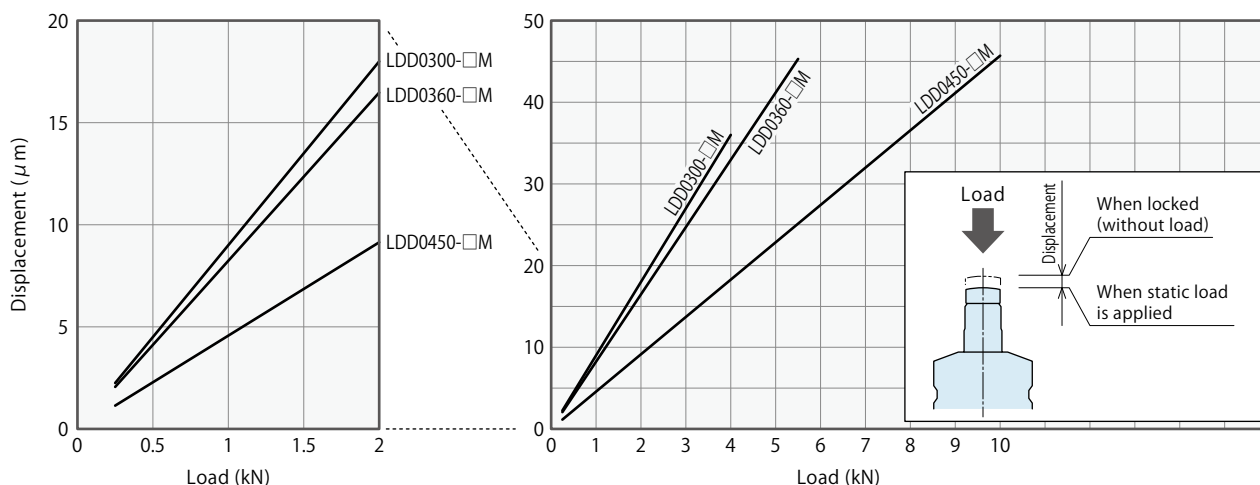

※ The displacement of LDD-□M : Air Sensing Option is larger than that of LDD : Standard Model.

Performance Curve (LDD-M-Q : Hydraulic Advance Air Sensing Option Long Stroke Model)

Applicable Model

LDD 036 0 - M - Q

1 Body Size **5** Option : Q

4 Plunger Action Confirmation : M

Support Force Graph ※ This graph shows the support force under static load condition.

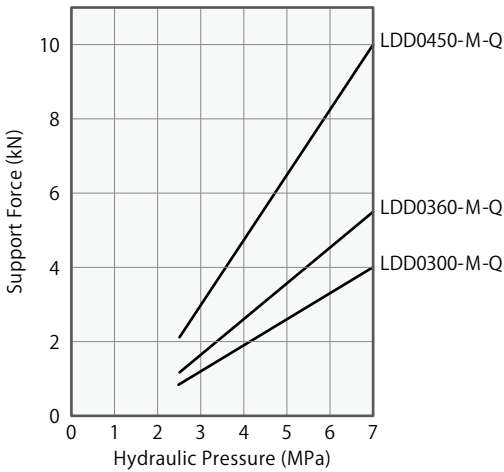

Model No. Hydraulic Pressure (MPa)	Support Force (kN)		
	LDD0300-M-Q	LDD0360-M-Q	LDD0450-M-Q
7	4.0	5.5	10.0
6.5	3.6	5.0	9.1
6	3.3	4.5	8.2
5.5	2.9	4.0	7.3
5	2.6	3.6	6.5
4.5	2.2	3.1	5.6
4	1.9	2.6	4.7
3.5	1.5	2.1	3.8
3	1.2	1.6	3.0
2.5	0.8	1.2	2.1
Support Force Formula ※1 kN	$0.70 \times P - 0.91$	$0.96 \times P - 1.25$	$1.75 \times P - 2.28$

Note : ※ 1. P : Operating Hydraulic Pressure (MPa)

Load / Displacement Graph ※ This graph shows the static load displacement at 7 MPa hydraulic pressure.

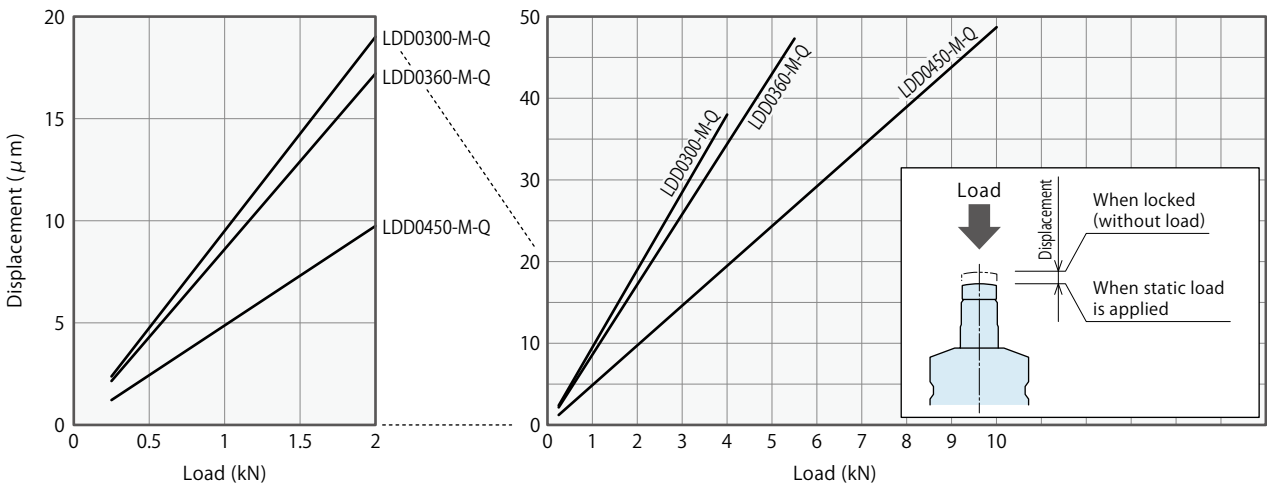

※ The displacement of LDD-M-Q : Air Sensing Option Long Stroke Model is larger than that of LDD : Standard Model.

External Dimensions

※This drawing shows the released state of LDD-□
(before the plunger is lifted).

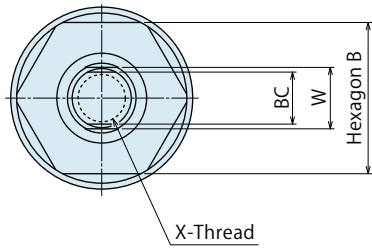

Contact Bolt Design Dimensions

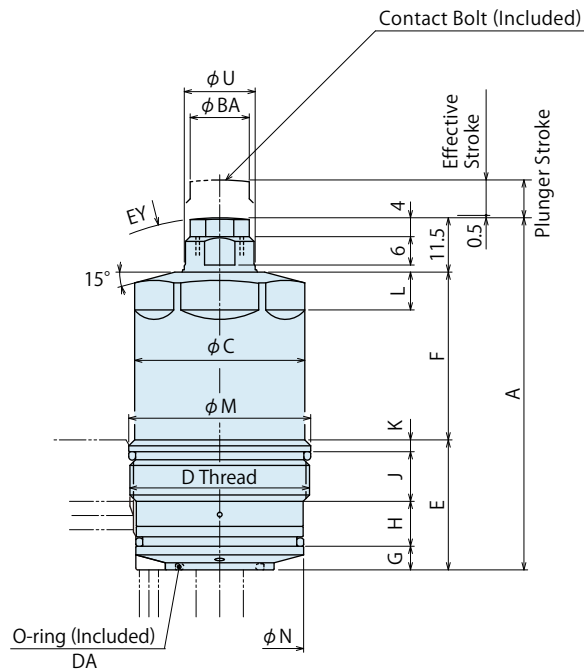
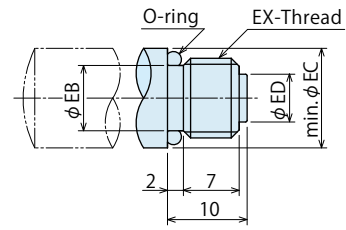

Machining Dimensions of Mounting Area

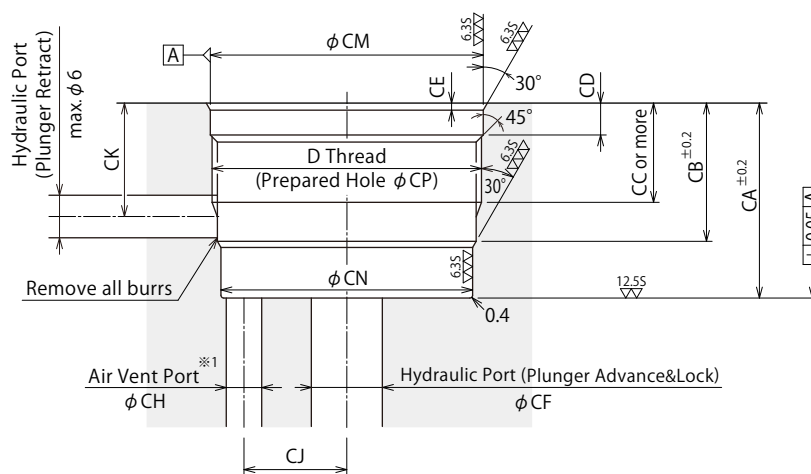

Note :

- ※ 1. Please keep clear condition at the air vent port, and prevent coolant and chips from entering the port.
(Please refer to "Appropriate Measures for the Air Vent Port (P.23)".)

Model No. Indication

(Format Example : LDD0450-H, LDD0300-L)

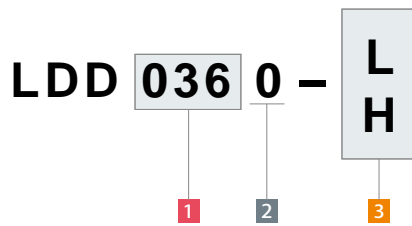

1 Body Size

2 Design No.

3 Plunger Spring Force

4 Plunger Action Confirmation (Blank)

5 Option

Blank : Hydraulic Advance Model (Standard)

External Dimensions and Machining Dimensions for Mounting

(mm)

Model No.	LDD0300-□	LDD0360-□	LDD0450-□
Plunger Stroke	8	8	10
Effective Stroke	7.5	7.5	9.5
A	79	74.5	89
B	27	32	41
C	30	36	45
D (Nominal × Pitch)	M32×1.5	M38×1.5	M48×1.5
E	27	27.5	31.5
F	40.5	35.5	46
G	4.5	5	2.5
H	9.5	9.5	12
J	10.5	10.5	13
K	2.5	2.5	4
L	8	8	11
M	32.5 ^{fr} _{-0.064} ^{+0.025}	38.5 ^{fr} _{-0.064} ^{+0.025}	49 ^{fr} _{-0.064} ^{+0.025}
N	29.5 ^{fr} _{-0.053} ^{+0.020}	35.5 ^{fr} _{-0.064} ^{+0.025}	45 ^{fr} _{-0.064} ^{+0.025}
U	12	15	16
W	10	13	13
X (Nominal × Pitch × Depth)	M8×1.25×12	M10×1.5×11	M10×1.5×11
BA	11.5	12.5	12.5
BC	10	11	11
CA	27	27.5	31.5
CB	19.5	19.5	23.5
CC	14	14	18
CD	4.5	4.5	7
CE	1	1	1.5
CF	max.10	max.10	max.12
CH	max.3	max.5	max.6
CJ	13	14.5	19
CK	16	16	20
CM	32.5 ^{H8} ₀ ^{+0.039}	38.5 ^{H8} ₀ ^{+0.039}	49 ^{H8} ₀ ^{+0.039}
CN	29.5 ^{H8} ₀ ^{+0.033}	35.5 ^{H8} ₀ ^{+0.039}	45 ^{H8} ₀ ^{+0.039}
CP	30.5 ^{+0.17} _{-0.12}	36.5 ^{+0.17} _{-0.12}	46.5 ^{+0.17} _{-0.12}
DA	AS568-015(90°)	AS568-016(90°)	AS568-017(90°)
EY	SR30	SR50	SR50
Tightening Torque for Main Body ※2	50 N·m	63 N·m	80 N·m

Note : ※2. The torque for mounting the body should be as indicated in the table above.
Excessive torque will cause deformation of the body leading to operation failure.
Also, with insufficient torque, O-ring will be damaged resulting in oil leakage.

Contact Bolt Design Dimensions

※ Reference for designing a contact bolt (attachment) by customer other than the included contact bolt.

(mm)

Corresponding Model No.	LDD0300-□	LDD0360-□	LDD0450-□
EB	6	8.2	8.2
EC	10	12.5	12.5
ED	5	6	6
EX (Nominal × Pitch)	M8×1.25	M10×1.5	M10×1.5
O-ring	S6 (Made by NOK)	S8 (Made by NOK)	S8 (Made by NOK)

External Dimensions

※This drawing shows the released state of LDD-Q (before the plunger is lifted).

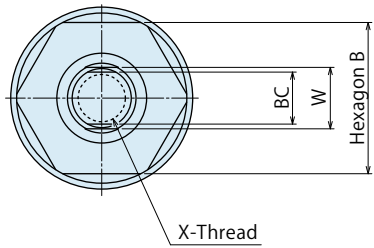

Contact Bolt Design Dimensions

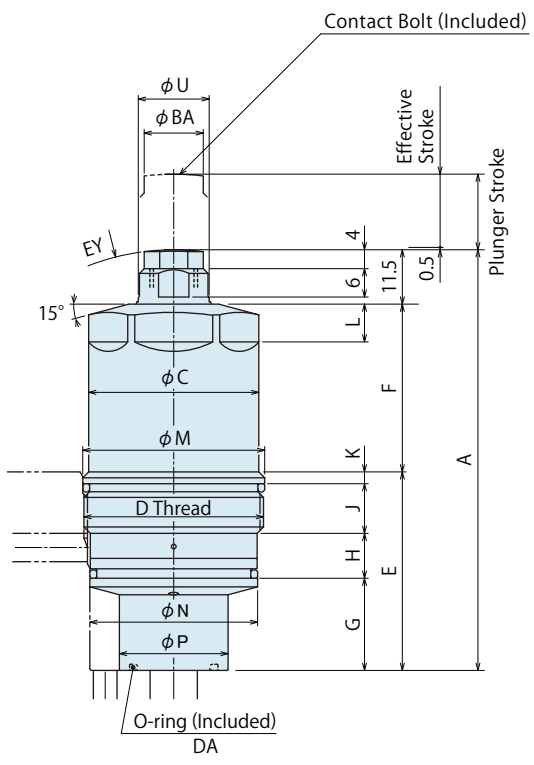
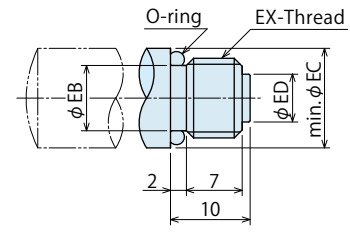

Machining Dimensions of Mounting Area

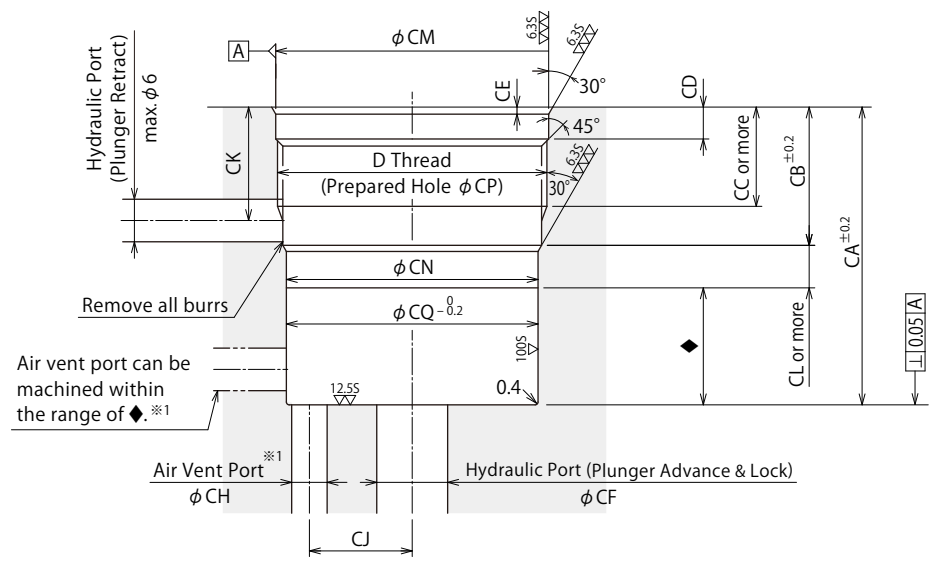

Note :
 ※ 1. Please keep clear condition at the air vent port, and prevent coolant and chips from entering the port.
 (Please refer to "Appropriate Measures for the Air Vent Port (P.23)".)

Model No. Indication

(Format Example : LDD0450-Q, LDD0300-Q)

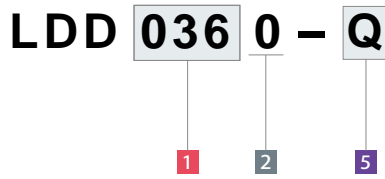

- 1 Body Size
 - 2 Design No.
 - 3 Plunger Spring Force
 - 4 Plunger Action Confirmation (Blank)
 - 5 Option
- Q : Hydraulic Advance Long Stroke Model

External Dimensions and Machining Dimensions for Mounting

(mm)

Model No.	LDD0300-Q	LDD0360-Q	LDD0450-Q
Plunger Stroke	16	16	20
Effective Stroke	15.5	15.5	19.5
A	95	89	106.5
B	27	32	41
C	30	36	45
D (Nominal × Pitch)	M32×1.5	M38×1.5	M48×1.5
E	43	42	49
F	40.5	35.5	46
G	20.5	19.5	20
H	9.5	9.5	12
J	10.5	10.5	13
K	2.5	2.5	4
L	8	8	11
M	32.5 ^{fr} _{-0.064} ^{-0.025}	38.5 ^{fr} _{-0.064} ^{-0.025}	49 ^{fr} _{-0.064} ^{-0.025}
N	29.5 ^{fr} _{-0.053} ^{-0.020}	35.5 ^{fr} _{-0.064} ^{-0.025}	45 ^{fr} _{-0.064} ^{-0.025}
P	22	23	27
U	12	15	16
W	10	13	13
X (Nominal × Pitch × Depth)	M8×1.25×12	M10×1.5×11	M10×1.5×11
BA	11.5	12.5	12.5
BC	10	11	11
CA	43	42	49
CB	19.5	19.5	23.5
CC	14	14	18
CD	4.5	4.5	7
CE	1	1	1.5
CF	max.10	max.10	max.12
CH	max.3	max.5	max.6
CJ	13	14.5	19
CK	16	16	20
CL	6	6	10
CM	32.5 ^{H8} ₀ ^{+0.039}	38.5 ^{H8} ₀ ^{+0.039}	49 ^{H8} ₀ ^{+0.039}
CN	29.5 ^{H8} ₀ ^{+0.033}	35.5 ^{H8} ₀ ^{+0.039}	45 ^{H8} ₀ ^{+0.039}
CP	30.5 ^{+0.17} _{-0.12}	36.5 ^{+0.17} _{-0.12}	46.5 ^{+0.17} _{-0.12}
CQ	29.5	35.5	45
DA	AS568-015(90°)	AS568-016(90°)	AS568-017(90°)
EY	SR30	SR50	SR50
Tightening Torque for Main Body ^{※2}	50 N·m	63 N·m	80 N·m

Note : ^{※2} The torque for mounting the body should be as indicated in the table above.
Excessive torque will cause deformation of the body leading to operation failure.
Also, with insufficient torque, O-ring will be damaged resulting in oil leakage.

Contact Bolt Design Dimensions

[※] Reference for designing a contact bolt (attachment) by customer other than the included contact bolt.

(mm)

Corresponding Model No.	LDD0300-Q	LDD0360-Q	LDD0450-Q
EB	6	8.2	8.2
EC	10	12.5	12.5
ED	5	6	6
EX (Nominal × Pitch)	M8×1.25	M10×1.5	M10×1.5
O-ring	S6 (Made by NOK)	S8 (Made by NOK)	S8 (Made by NOK)

External Dimensions

※ This drawing shows the released state of LDD-□M (before the plunger is lifted). Refer to Hydraulic Advance Model (Standard) (P.11, P.12) for unlisted dimensions.

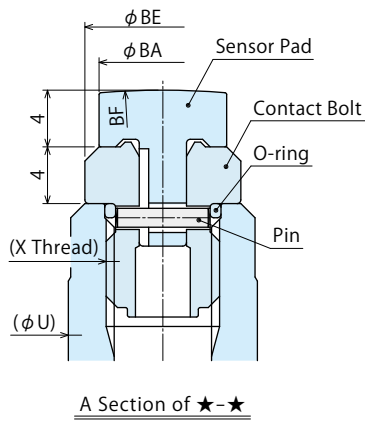
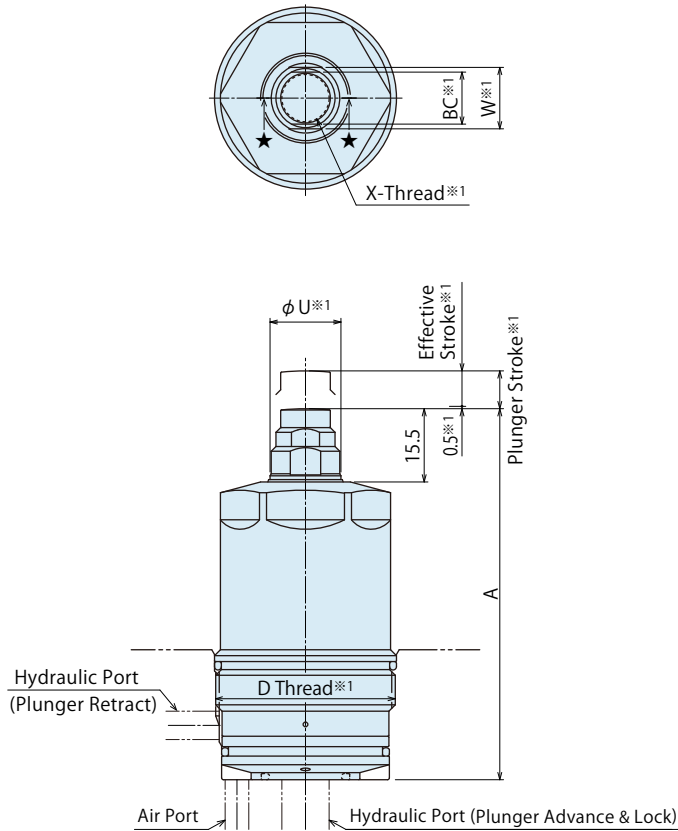

Notes :

- ※1. Dimensions with ※1 are the same as LDD Standard Model.
- 1. Please refer to P.20 for Air Sensing Chart.

Sensor Pad Design Dimensions

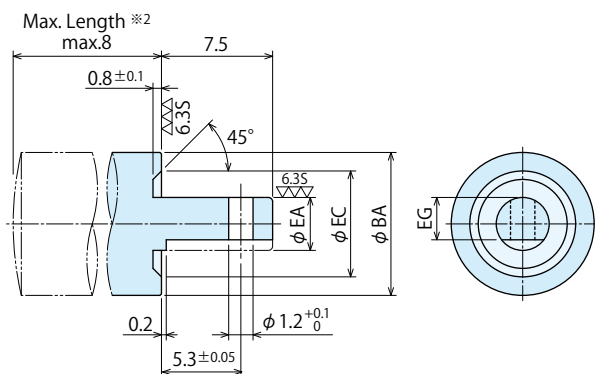

※ When changing the sensor pad, please design it according to the sensor pad design dimensions. (Please contact us when changing the contact bolt.)

Workpiece Contact Force Curve (Reference)

This graph shows the workpiece contact force (reference value) when a work support with Plunger Spring Force **H** : High Spring contacts a workpiece in the middle of plunger stroke.

※ Refer to P.19 for the calculation formula of workpiece contact force.

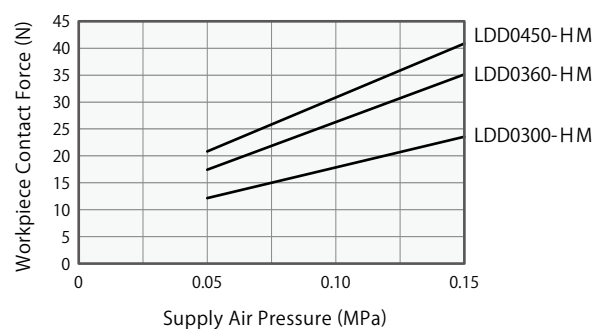

Model No. Indication

(Format Example : LDD0450-HM, LDD0300-LM)

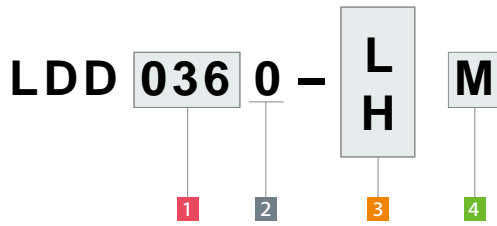

- 1 Body Size
- 2 Design No.
- 3 Plunger Spring Force
- 4 Plunger Action Confirmation
M : Air Sensing Option
- 5 Option
Blank : Hydraulic Advance Model (Standard)

External Dimensions and Machining Dimensions for Mounting

(mm)

Model No.	LDD0300-□M	LDD0360-□M	LDD0450-□M
Plunger Stroke ※1	8	8	10
Effective Stroke ※1	7.5	7.5	9.5
A	83	78.5	93
D (Nominal × Pitch) ※1	M32×1.5	M38×1.5	M48×1.5
U ※1	12	15	16
W ※1	10	13	13
X (Nominal × Pitch × Depth) ※1	M8×1.25×12	M10×1.5×11	M10×1.5×11
BA	9.5	10.5	10.5
BC ※1	10	11	11
BE	11.5	12.5	12.5
BF	SR30	SR50	SR50
Pin (Diameter × Length)	φ1×5.8	φ1×7.8	φ1×7.8
O-ring	S6 (Made by NOK)	S8 (Made by NOK)	S8 (Made by NOK)

Note : ※ 1. Dimensions with ※1 are the same as LDD Standard Model.

Sensor Pad Design Dimension List

(mm)

Corresponding Model No.	LDD0300-□M	LDD0360-□M	LDD0450-□M
EA	3g7 ^{-0.002} _{-0.012}	4g7 ^{-0.004} _{-0.016}	4g7 ^{-0.004} _{-0.016}
EC	7.5	8.5	8.5
EG	2.1	3.2	3.2

Note : ※ 2. Sensor response may decrease if the pad is longer than maximum length.

External Dimensions

※ This drawing shows the released state of LDD-M-Q (before the plunger is lifted). Refer to Hydraulic Advance Long Stroke Model (P.13, P.14) for unlisted dimensions.

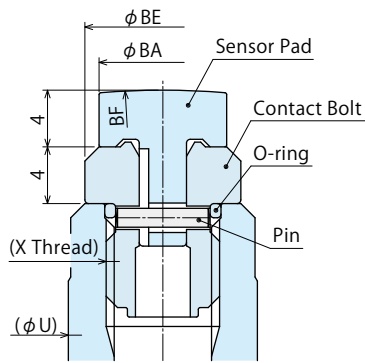
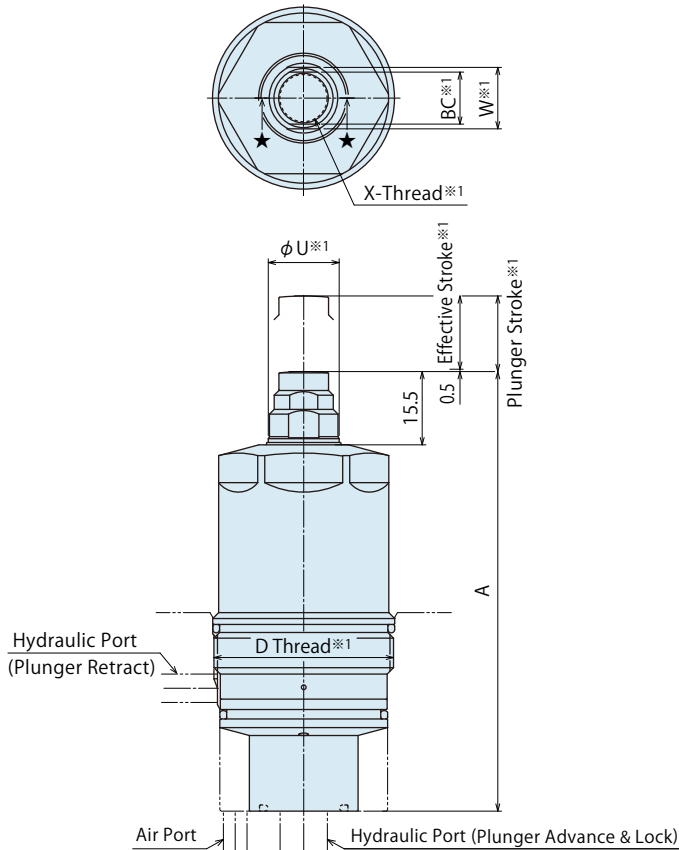

A Section of ★-★

Notes :

- ※1. Dimensions with ※1 are the same as LDD-Q Long Stroke Model.
- 1. Please refer to P.20 for Air Sensing Chart.

Sensor Pad Design Dimensions

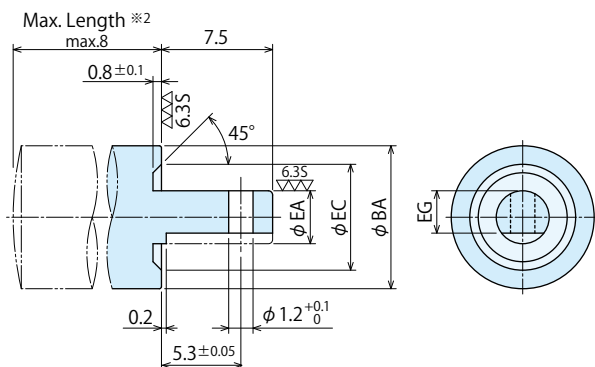

※ When changing the sensor pad, please design it according to the sensor pad design dimensions. (Please contact us when changing the contact bolt.)

Workpiece Contact Force Curve (Reference)

This graph shows the workpiece contact force (reference value) when a work support contacts a workpiece in the middle of plunger stroke.

※ Refer to P.19 for the calculation formula of workpiece contact force.

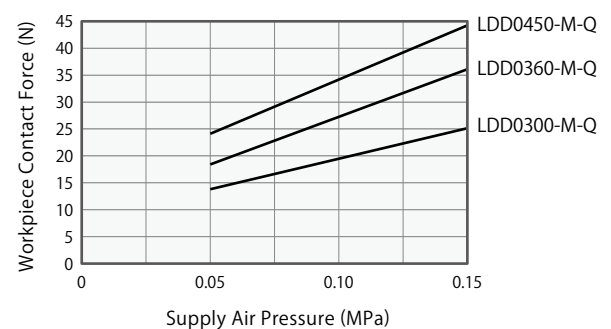

Model No. Indication

(Format Example : LDD0450-M-Q, LDD0300-M-Q)

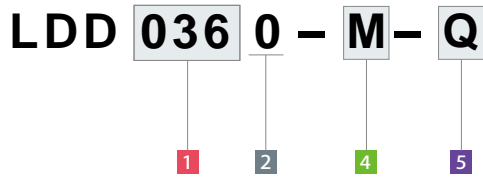

- 1 Body Size
- 2 Design No.
- 3 Plunger Spring Force (Blank)
- 4 Plunger Action Confirmation
M : Air Sensing Option
- 5 Option
Q : Hydraulic Advance Long Stroke Model

External Dimensions and Machining Dimensions for Mounting

Model No.	LDD0300-M-Q	LDD0360-M-Q	LDD0450-M-Q
Plunger Stroke ※1	16	16	20
Effective Stroke ※1	15.5	15.5	19.5
A	99	93	110.5
D (Nominal × Pitch) ※1	M32×1.5	M38×1.5	M48×1.5
U ※1	12	15	16
W ※1	10	13	13
X (Nominal × Pitch × Depth) ※1	M8×1.25×12	M10×1.5×11	M10×1.5×11
BA	9.5	10.5	10.5
BC ※1	10	11	11
BE	11.5	12.5	12.5
BF	SR30	SR50	SR50
Pin (Diameter × Length)	φ1×5.8	φ1×7.8	φ1×7.8
O-ring	S6 (Made by NOK)	S8 (Made by NOK)	S8 (Made by NOK)

Note : ※ 1. Dimensions with ※1 are the same as LDD-Q Long Stroke Model.

Sensor Pad Design Dimension List

Corresponding Model No.	LDD0300-M-Q	LDD0360-M-Q	LDD0450-M-Q
EA	3g7 ^{-0.002} _{-0.012}	4g7 ^{-0.004} _{-0.016}	4g7 ^{-0.004} _{-0.016}
EC	7.5	8.5	8.5
EG	2.1	3.2	3.2

Note : ※ 2. Sensor response may decrease if the pad is longer than maximum length.

● Air Sensing Option (Plunger Action Confirmation · · · M : Air Sensing Option)

Plunger action is detected by the circuit at the vent port like the drawing below. This is done by detecting the differential pressure between P1 and P2 with air catch sensor.

Applicable Model

LDD 0360 -

L	H
---	---

 -

M	Blank
Q	

4 Plunger Action Confirmation : M

- Workpieces even with rough, casting or forged surface can be accurately detected since the structure does not detect the workpiece surface directly.
- Detected with higher accuracy compared to a switch detection with a dog, etc.
- Designed to prevent coolant from entering into the sensing area.

Structure Drawing

Recommended Operating Air Pressure : 0.05 ~ 0.15MPa

Recommended Air Catch Sensor

Manufacturer	SMC	CKD
Name	Air Catch Sensor	Gap Switch
Model No.	ISA3-G	GPS3-E

- The Number of Work Supports Connected per Air Sensor : 1 ~ 4

LDD Released State (Air Sensor OFF)

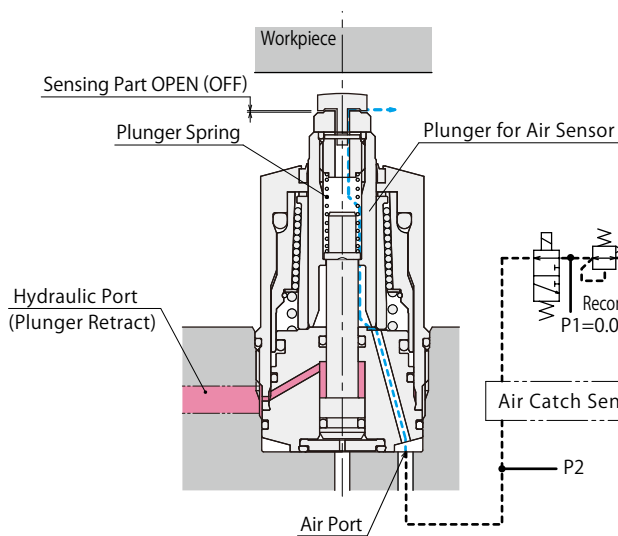

LDD Plunger Extends • Contacts Workpiece (Air Sensor ON)

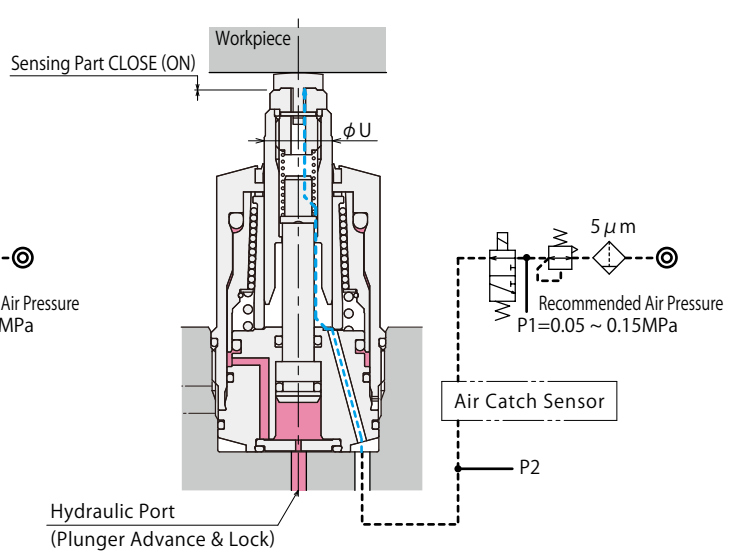

Workpiece Contact Force Formula when using Air Sensor ※1

$$\text{Workpiece Contact Force (N)} = \text{Plunger Spring Force (N)} + \text{Supply Air Pressure (MPa)} \times U^2 (\text{mm}) \times \pi / 4$$

Model No.		LDD0300-□M	LDD0360-□M	LDD0450-□M
		LDD0300-M-Q	LDD0360-M-Q	LDD0450-M-Q
U	mm	12	15	16
Plunger ※2 Spring Force N	L : Low Spring Force	3.6 ~ 5.7	4.7 ~ 7.8	5.8 ~ 9.7
	H : High Spring Force	4.9 ~ 8.0	6.2 ~ 11.0	7.9 ~ 13.6
	Q : Long Stroke Model	4.9 ~ 11.4	6.2 ~ 12.9	7.8 ~ 20.4

Notes :

※1. Please prepare a stopper if necessary when using light and/or thin workpiece. Otherwise it might be pushed up by work support.

※2. The plunger spring force indicates the spring design value.

It may vary depending on sliding resistance of the plunger and characteristic of the spring, etc. Please read it as a reference value of workpiece contact force.

Air Sensing Chart

Connect one work support with one air catch sensor
Supply Pressure of Air Catch Sensor P1=0.15MPa

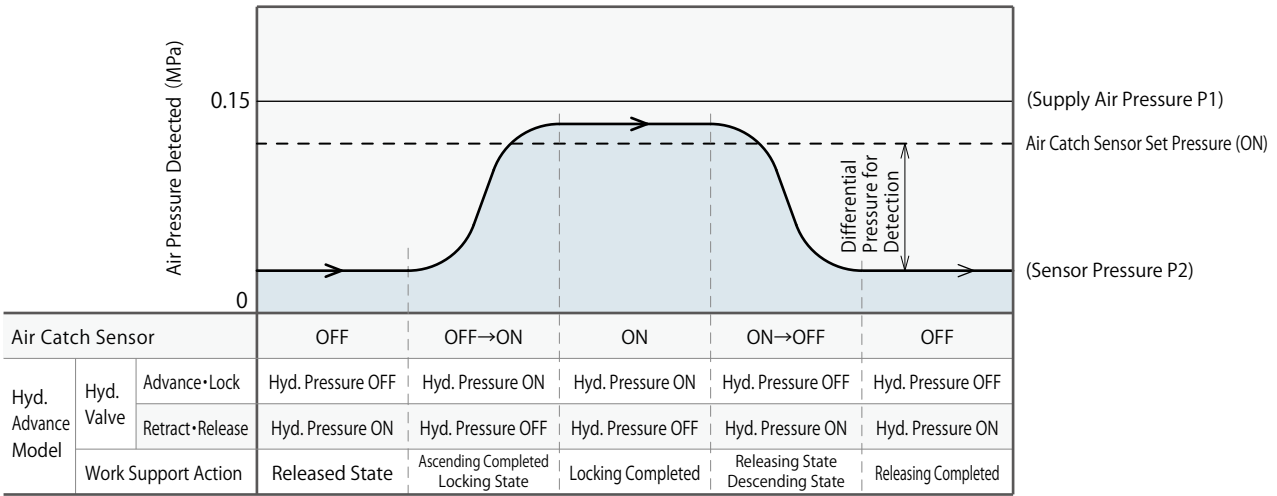

Note : 1. Depending on the usage condition, the detection differential pressure may be decreased by repeated action. Please contact us for overhaul when the detection differential pressure is decreased.

Connect four work supports with one air catch sensor
Supply Pressure of Air Catch Sensor P1=0.15MPa

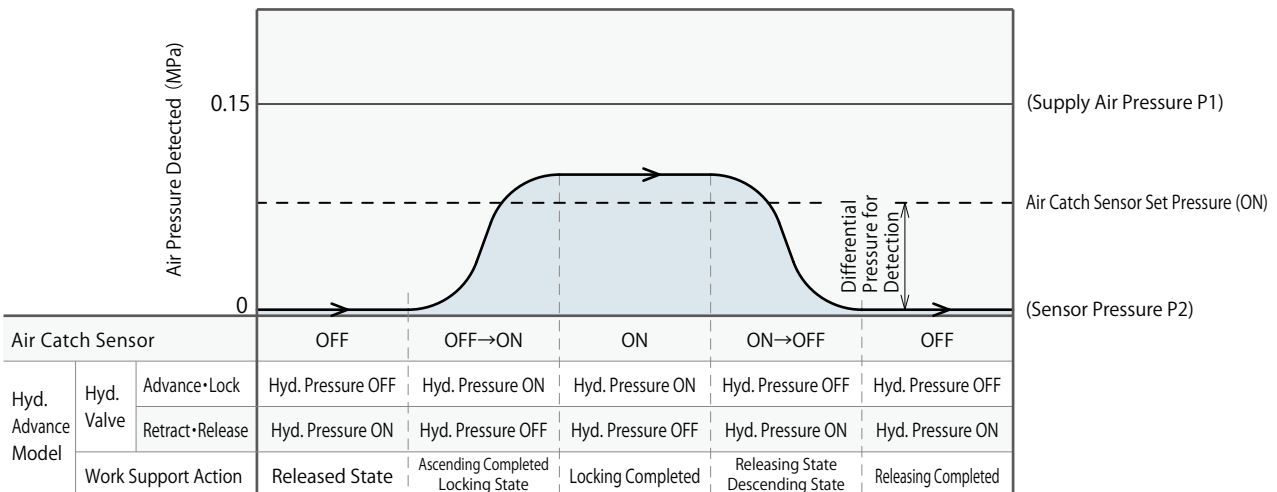

Notes : 1. Depending on the usage condition, the detection differential pressure may be decreased by repeated action. Please contact us for overhaul when the detection differential pressure is decreased.
2. In order to carry out stabilized detection, the number of work supports connected per air sensor should be four or less.

Notes

- This specification is designed for confirming the plunger action of the work support.
If it is used for confirming the close contact with the workpiece, other clamping (force) is necessary.
- If the plunger goes up too fast, it may bounce back and locks itself. Resulting in a gap with the workpiece and possible damage to the internal parts due to the impact force. Set the plunger action time at 0.5-1.0 sec. to adjust the air supply with the flow control valve with check valve (meter-in), and make sure that there is no clearance with the workpiece for operation.
- Continuously supply air pressure to the air port when it is used in the condition where cutting fluids or cutting chips may enter into the product. When used without air supply, contaminants will enter from the sensor pad part causing supporting failure and damage to the air sensor, etc.

● Air Purge Function

The special dust seal that features low friction and high sealing capabilities is used in LDD. However, when using LDD in worse condition, air purge function is available by providing the circuit to the air vent port like the drawing below.

Structure Drawing

LDD Plunger Descending and at Releasing State

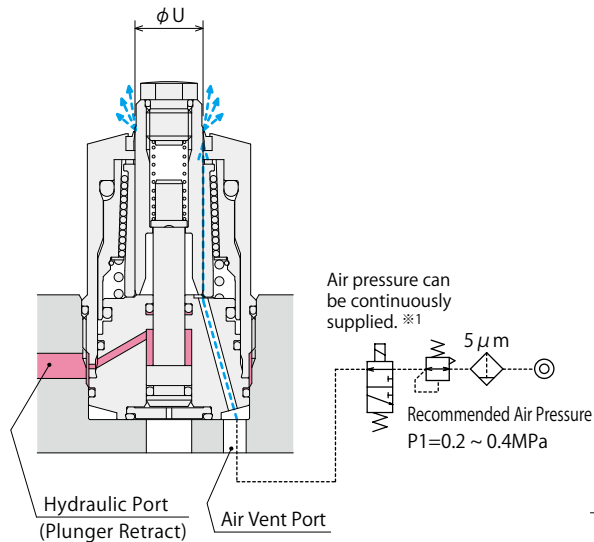

LDD Plunger Ascending and at Locking State

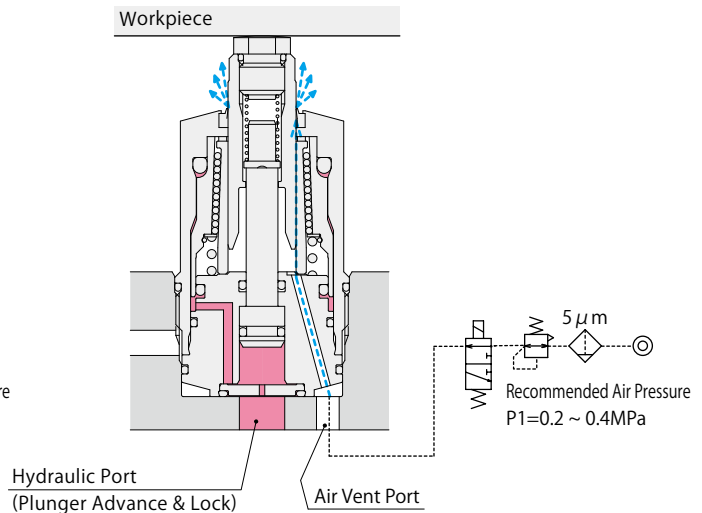

Workpiece Contact Force Formula when Using Air Purge Function ※2

$$\text{Workpiece Contact Force (N)} = \text{Plunger Spring Force (N)} + \text{Supply Air Pressure (MPa)} \times U^2 (\text{mm}) \times \pi / 4$$

Model No.		LDD0300-□ LDD0300-Q	LDD0360-□ LDD0360-Q	LDD0450-□ LDD0450-Q
U	mm	12	15	16
Plunger ※3 Spring Force N	L : Low Spring Force	3.6 ~ 5.7	4.7 ~ 7.8	5.8 ~ 9.7
	H : High Spring Force	4.9 ~ 8.0	6.2 ~ 11.0	7.9 ~ 13.6
	Q : Long Stroke Model	4.9 ~ 11.4	6.2 ~ 12.9	7.8 ~ 20.4

Notes :

※2. Please prepare a stopper if necessary when using light and/or thin workpiece. Otherwise it might be pushed up by work support.

※3. The plunger spring force indicates the spring design value.

It may vary depending on sliding resistance of the plunger and characteristic of the spring, etc. Please read it as a reference value of workpiece contact force.

Notes

※1. In case of continuous air purge, use it with 2.5MPa hydraulic pressure or more.

1. If the plunger ascends too fast, it may bounce back and locks itself resulting in a gap with the workpiece, and possible damage to the internal parts due to the impact. Set the plunger action time at 0.5-1.0 sec. to adjust the air supply with the flow control valve with check valve (meter-in), and make sure that there is no clearance with the workpiece for operation.
2. Air cannot be vented as the air supply pressure is too low because the cracking pressure at the dust seal lip is about 0.1MPa.

● Plunger Spring Design Dimension

※ Reference for designing a plunger spring by customer other than the included plunger spring.

※ This drawing shows the released state.

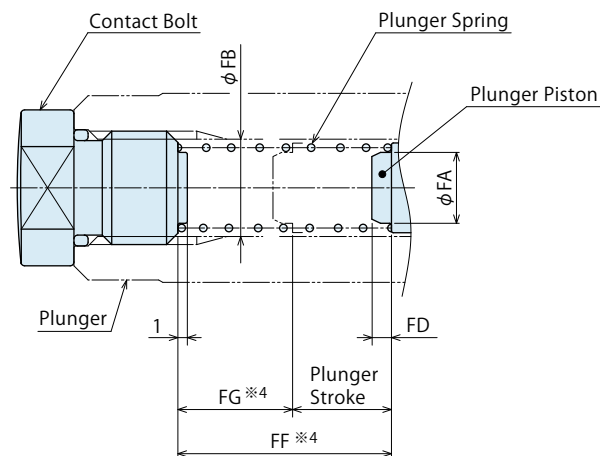

(mm)

Corresponding Model No.	LDD0300-□ LDD0300-□M	LDD0360-□ LDD0360-□M	LDD0450-□ LDD0450-□M
FA	5	6	6
FB	6.8	8.5	8.5
FD	3.9	8.1	8.1
FF ^{※4}	24.6	17.6	19.6
FG ^{※4}	16.6	9.6	9.6
Stroke	8	8	10

(mm)

Corresponding Model No.	LDD0302-Q LDD0302-M-Q	LDD0360-Q LDD0360-M-Q	LDD0450-Q LDD0450-M-Q
FA	5	6	6
FB	6.8	8.5	8.5
FD	3.9	8.1	8.1
FF ^{※4}	26.6	28.6	36.2
FG ^{※4}	10.6	12.6	16.2
Stroke	16	16	20

Note :

※ 4. When designing a spring, make sure that the spring set length is below FF dimension and the spring contact length is below FG dimension.

Cautions

Notes for Design

- 1) Check Specifications
 - Please use each product according to the specifications.
 - When using a work support opposite to the clamp, set the support force at more than 1.5 times the clamping force.

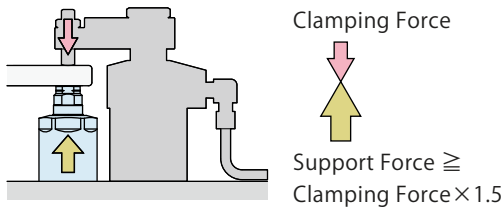

2) Notes for Circuit Design

- Please read "Notes on Hydraulic Cylinder Speed Control Unit" for proper hydraulic circuit design. Improper circuit design may lead to malfunctions and damages. (Refer to P.25)

3) Install a temporary stopper for a workpiece if necessary.

- When multiple work supports are used for a light workpiece, the plunger spring force may be higher than the workpiece weight, causing the workpiece to be pushed up.

4) An attachment is required for the plunger.

- Make sure that an attachment is installed to the plunger. Otherwise, the plunger does not advance since the plunger spring is free to move.
- Make sure to set the O-ring to the attachment. Otherwise, cutting fluid or other contaminants will get in easily, causing malfunction.

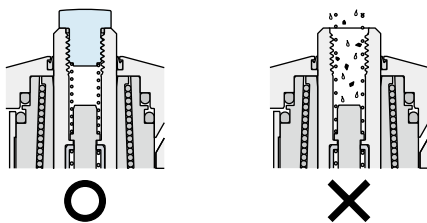

5) Protect the plunger surface when using on a welding fixture.

- If spatter attaches to the sliding surface it may lead to a sliding failure and an insufficient support function.

6) Adjust the plunger operation time with flow rate.

- A rough guideline for the full stroke is between 0.5 and 1 second.
- Use a flow regulating valve with a check valve (meter-in).
- In case of a meter-out circuit, the circuit pressure can be increased during cylinder operation depending on supply oil amount.
- If the action speed is too fast, the plunger may bounce back and locks itself resulting in a gap with the workpiece.

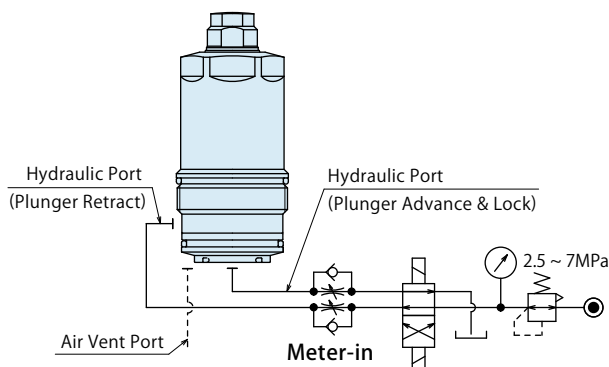

7) Appropriate Measures for Air Vent Port

- The work support, although only slightly, breathes like a single-acting cylinder. Consider the environment and avoid cutting fluid, coolant or any contaminants.
- If using it without air vent port, it will not function properly. Make sure it breathes without the influence of cutting chips or coolant.

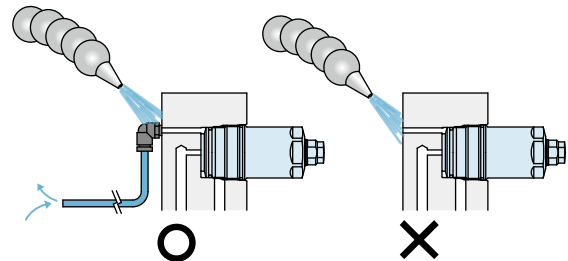

8) Make sure that offset load and component of force do not affect the product.

- If using the product as illustrated below, the displacement against load will be increased. Also large load will damage the internal parts.

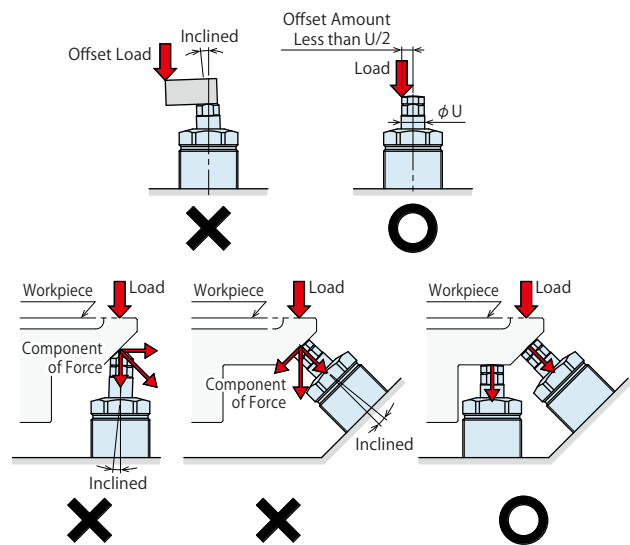

9) The Weight of an Attachment

- When designing an attachment, make sure the attachment weight is 30% or less of the plunger spring force.

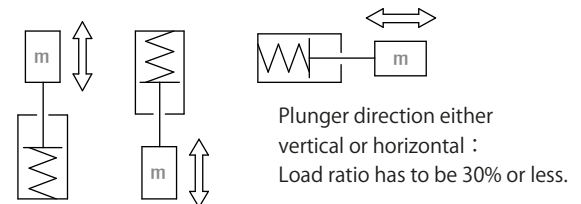

- Ex.) In case of LDD0300-L with the plunger spring force 3.6-5.7N. The maximum weight of the contact bolt = $3.6 \times 0.3 / 9.807 = 0.11 \text{ kg}$. Since it may vary depending on sliding resistance of the plunger and characteristic of the spring, it is recommended to design the contact bolt as light as possible.

- The dimensions of the mounting thread area need to be processed according to the design dimensions for contact bolts as shown on the respective product pages.
- Since the attachment is also used for fixing the plunger spring, if the dimensions of thread part are different, it will cause spring force fluctuation or damage leading to malfunction.

● Installation Notes

1) Check the Usable Fluid

- Please use the appropriate fluid by referring to the Hydraulic Fluid List.

2) Procedure before Piping

- The pipeline, piping connector and fixture circuits should be cleaned by thorough flushing.
- The dust and cutting chips in the circuit may lead to fluid leakage and malfunction.
- There is no filter provided with Kosmek's product except for a part of valves which prevents contaminants from getting into the circuit.

3) Applying Sealing Tape

- Wrap with tape 1 to 2 times following the screw direction.
- Pieces of the sealing tape can lead to oil leakage and malfunction.
- In order to prevent contaminants from going into the product during the piping work, it should be carefully cleaned before working.

4) Installation of the Product

- For LDD (Threaded Model), be careful not to damage the O-ring, and tighten them with the torque shown in the table below.

Model No.	Thread Size	Tightening Torque (N·m)
LDD0300	M32×1.5	50
LDD0360	M38×1.5	63
LDD0450	M48×1.5	80

- Apply an adequate amount of grease to the O-ring.
- If it is mounted under dry state, the O-ring may have twisting or be defective.
- If it is tightened with higher torque, it may lead to malfunction.

5) Replacement of Attachment

- Do not lose the plunger spring when removing the attachment (contact bolt).
- When mounting the attachment, stop the plunger with a spanner at edge and tighten it with torque as shown in the table below.

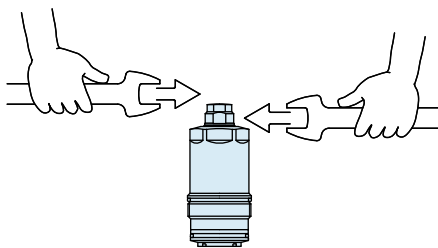

Model No.	Head Thread Size	Tightening Torque (N·m)
LDD0300	M8×1.25	10
LDD0360	M10×1.5	16
LDD0450	M10×1.5	16

6) Air Bleeding of the Hydraulic Circuit

- If the hydraulic circuit has excessive air, the action time may become very long. If air enters the circuit after connecting the hydraulic port or under the condition of no air in the oil tank, please perform the following steps.

- ① Reduce hydraulic pressure to less than 2MPa.
- ② Loosen the cap nut of pipe fitting closest to the clamp by one full turn.
- ③ Wiggle the pipeline to loosen the outlet of pipe fitting. Hydraulic fluid mixed with air comes out.

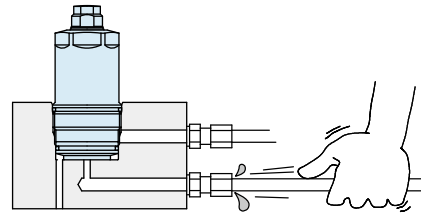

- ④ Tighten the cap nut after bleeding.
- ⑤ It is more effective to release the air at the highest point inside the circuit or at the end of the circuit.

7) Checking Looseness and Retightening

- At the beginning of the product installation, the bolt and nut may be tightened lightly. Check the looseness and re-tighten as required.

● Hydraulic Fluid List

Maker	ISO Viscosity Grade ISO-VG-32	
	Anti-Wear Hydraulic Oil	Multi-Purpose Hydraulic Oil
Showa Shell Sekiyu	Tellus S2 M 32	Morlina S2 B 32
Idemitsu Kosan	Daphne Hydraulic Fluid 32	Daphne Super Multi Oil 32
JX Nippon Oil & Energy	Super Hyrando 32	Super Mulpus DX 32
Cosmo Oil	Cosmo Hydro AW32	Cosmo New Mighty Super 32
ExxonMobil	Mobil DTE 24	Mobil DTE 24 Light
Matsumura Oil	Hydol AW-32	
Castrol	Hyspin AWS 32	

Note: Please contact manufacturers when customers require products in the list above.

Cautions

● Notes on Hydraulic Cylinder Speed Control Unit



Please pay attention to the cautions below. Design the hydraulic circuit for controlling the action speed of hydraulic cylinder. Improper circuit design may lead to malfunctions and damages. Please review the circuit design in advance.

● Flow Control Circuit for Single Acting Cylinder

For spring return single-acting cylinders, restricting flow during release can extremely slow down or disrupt release action. The preferred method is to use a flow control valve with a check valve and control the flow during the lock action only. It is also preferred to provide a flow control valve at each actuator which has limited action speed (swing clamp, hydraulic compact cylinder, etc.)

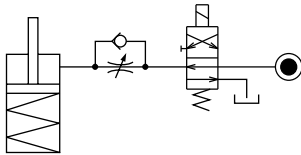

If the cylinder may be damaged by the load from the release action direction, provide a flow control valve to the releasing side as well. (Provide a flow control valve to the releasing side if the lever weight is applied during release action.)

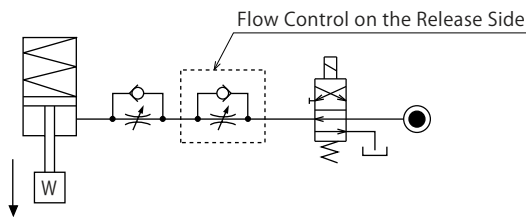

● Flow Control Circuit for Double Acting Cylinder

Flow control circuit for double acting cylinder (except LDD, LKE, TLA, TMA and TND) should have meter-out circuits for both the lock and release sides. Meter-in control can have adverse effect by presence of air in the system.

However, in the case of controlling LDD, LKE, TLA, TMA and TND, both lock side and release side should be meter-in circuit. For LDD, TMA, TLA and TND, if meter-out circuit is used, abnormal high pressure is created, which causes oil leakage and damage.

【Meter-out Circuit】 (Except LDD, LKE, TMA, TLA and TND)

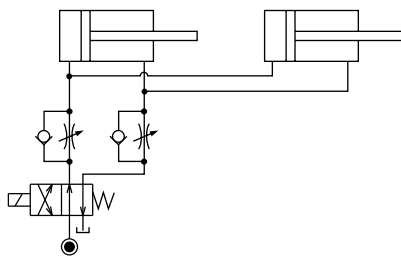

【Meter-in Circuit】

LDD, LKE, TLA, TMA and TND must be controlled with meter-in.

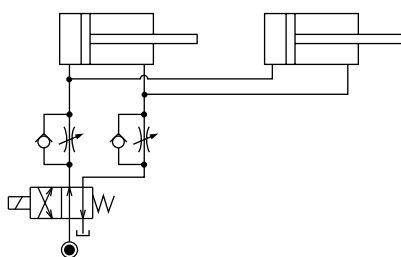

In the case of meter-out circuit, the hydraulic circuit should be designed with the following points.

- ① Single acting components should not be used in the same flow control circuit as the double acting components. The release action of the single acting cylinders may become erratic or very slow.

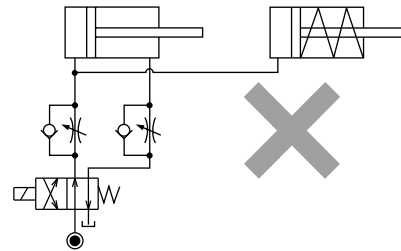

Refer to the following circuit when both the single acting cylinder and double acting cylinder are used together.

- Separate the control circuit.

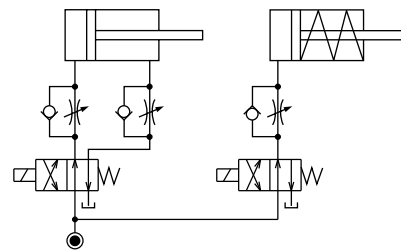

- Reduce the influence of double acting cylinder control unit. However, due to the back pressure in tank line, single acting cylinder is activated after double acting cylinder works.

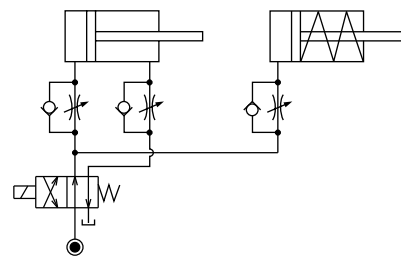

- ② In the case of meter-out circuit, the inner circuit pressure may increase during the cylinder action because of the fluid supply. The increase of the inner circuit pressure can be prevented by reducing the supplied fluid beforehand via the flow control valve. Especially when using sequence valve or pressure switches for clamping detection. If the back pressure is more than the set pressure then the system will not work as it is designed to.

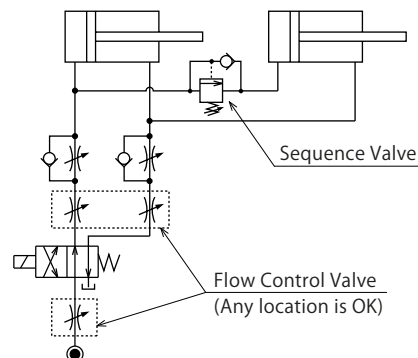

● Notes on Handling

- 1) It should be operated by qualified personnel.
 - The hydraulic machine and air compressor should be operated and maintained by qualified personnel.
- 2) Do not operate or remove the machine unless the safety protocols are ensured.
 - ① The machine and equipment can only be inspected or prepared when it is confirmed that the safety devices are in place.
 - ② Before removing the product, make sure that the above-mentioned safety devices are in place. Shut off the pressure and power source, and make sure no pressure exists in the hydraulic and air circuits.
 - ③ After stopping the product, do not remove until the temperature drops.
 - ④ Make sure there is no abnormality in the bolts and respective parts before restarting the machine or equipment.
- 3) Do not touch the plunger while the work support is working. Otherwise, your hands may be injured.



- 4) Do not disassemble or modify.
 - If the product is taken apart or modified, the warranty will be voided even within the warranty period.

● Warranty

- 1) Warranty Period
 - The product warranty period is 18 months from shipment from our factory or 12 months from initial use, whichever is earlier.
- 2) Warranty Scope
 - If the product is damaged or malfunctions during the warranty period due to faulty design, materials or workmanship, we will replace or repair the defective part at our expense. Defects or failures caused by the following are not covered.
 - ① If the stipulated maintenance and inspection are not carried out.
 - ② Failure caused by the use of the non-confirming state at the user's discretion.
 - ③ If it is used or handled in inappropriate way by the operator. (Including damage caused by the misconduct of the third party.)
 - ④ If the defect is caused by reasons other than our responsibility.
 - ⑤ If repair or modifications are carried out by anyone other than Kosmek, or without our approval and confirmation, it will void warranty.
 - ⑥ Other caused by natural disasters or calamities not attributable to our company.
 - ⑦ Parts or replacement expenses due to parts consumption and deterioration. (Such as rubber, plastic, seal material and some electric components.)

Damages excluding from direct result of a product defect shall be excluded from the warranty.

● Maintenance and Inspection

- 1) Removal of the Product and Shut-off of Pressure Source
 - Before removing the product, make sure that safety devices and preventive devices are in place. Shut off the pressure and power source, and make sure no pressure exists in hydraulic and air circuits.
 - Make sure there is no abnormality in the bolts and respective parts before restarting.
- 2) Regularly clean the area around the piston rod and plunger.
 - If it is used when the surface is contaminated with dirt, it may lead to packing seal damage, malfunctioning and fluid leakage.

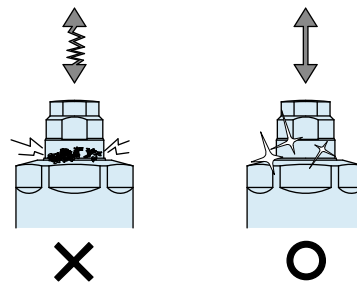

- 3) If disconnecting by couplers on a regular basis, air bleeding should be carried out daily to avoid air mixed in the circuit.
- 4) Regularly tighten piping, attachment and work support to ensure proper use.
- 5) Make sure the hydraulic fluid has not deteriorated.
- 6) Make sure there is a smooth action without an irregular noise.
 - Especially when it is restarted after left unused for a long period, make sure it can be operated correctly.
- 7) The products should be stored in the cool and dark place without direct sunshine or moisture.
- 8) Please contact us for overhaul and repair.



KOSMEK LTD.

▶ <http://www.kosmek.com/>

HEAD OFFICE 1-5, 2-chome, Murotani, Nishi-ku, Kobe-city, Hyogo, Japan 651-2241
TEL.+81-78-991-5162 FAX.+81-78-991-8787

United States of America SUBSIDIARY	KOSMEK (USA) LTD. 650 Springer Drive, Lombard, IL 60148 USA TEL. +1-630-620-7650 FAX. +1-630-620-9015
MEXICO REPRESENTATIVE OFFICE	KOSMEK USA Mexico Office Av. Santa Fe 103, Int. 59, col. Santa Fe Juriquilla, Queretaro, QRO, 76230, Mexico TEL. +52-1-55-3044-9983
EUROPE SUBSIDIARY	KOSMEK EUROPE GmbH Schleppeplatz 2 9020 Klagenfurt am Wörthersee Austria TEL. +43-463-287587 FAX. +43-463-287587-20
CHINA SUBSIDIARY	KOSMEK (CHINA) LTD. Room601, RIVERSIDE PYRAMID No.55, Lane21, Pusan Rd, Pudong Shanghai 200125, China TEL. +86-21-54253000
INDIA BRANCH OFFICE	KOSMEK LTD. - INDIA 4A/Old No:649, Ground Floor, 4th D cross, MM Layout, Kavalbyrasandra, RT Nagar, Bangalore -560032 India TEL.+91-9880561695
THAILAND REPRESENTATIVE OFFICE	KOSMEK Thailand Representation Office 67 Soi 58, RAMA 9 Rd., Phatthanakan, Suanluang, Bangkok 10250, Thailand TEL. +66-2-300-5132 FAX. +66-2-300-5133

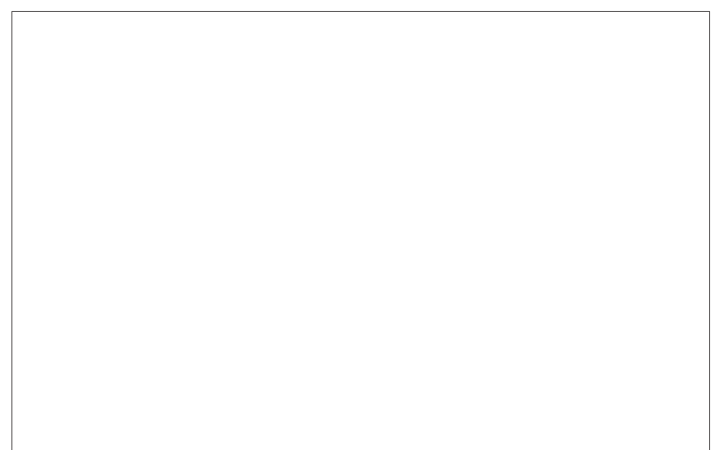

- For Further Information on Unlisted Specifications and Sizes, Please call us.
- Specifications in this Leaflet are Subject to Change without Notice.



JQA-QMA10823
KOSMEK HEAD OFFICE