



The Latest Product

Robotic Hand Changer

model **SWR2300**

High-Payload (230~360kg) Robotic Hand Changer Now On Sale

3 μ m Repeatability (when Connected)

Non-backlash mechanism allows zero backlash when connected thus enables 3 μ m repeatability even with High-Payload Tool Changer. Fluctuation of the edge is extremely small even with large tools and it secures the aimed position.

High Rigidity with Non-Backlash Mechanism

Equipped with Kosmek exclusive non-backlash mechanism, making it highly rigid and strong to "bending" and "twisting".

A Wide Variety of Electrodes

Select from a wide variety of electrodes, the same options for SWR 3kg ~ 120kg payload.



Light and Compact

High payload (230~360kg) yet light and compact hand changer with its product weight : 7.1kg master side + 4.8kg tool side, and body size : ϕ 207 outer diameter, 94mm thickness at connection.

High Safety

Built-in self-locking spring enables to maintain connected state at 2.8 kN and prevent tools from falling.

※ Usually it should be connected with spring force and air pressure.

Specifications ※ Refer to the product catalog on Kosmek website for detailed specifications.

Payload	kg	at 0.5MPa	230
		at 0.7MPa	360
Repeatability	mm		0.003
Holding Force	kN	at 0MPa ※1	2.8
Lift Stroke (Detaching Stroke)	mm		1.0
Allowable Static Moment	Bending		1800
	Twisting		1400
Product Weight (Body Part)	kg	Master Side	7.1
		Tool Side	4.8
Air Port			Rc3/8×10 Ports
Operating Air Pressure	MPa	Max. Pressure	0.7
		Min. Pressure	0.35
		Withstanding Pressure	1.05
Operating Temperature	°C		0~70
Usable Fluid			Dry Air

Air Port with Check Valve Option Available

The option has Check Valve (Metal Seal) on the air port connection part which supplies air from the master cylinder side to the tool adapter.

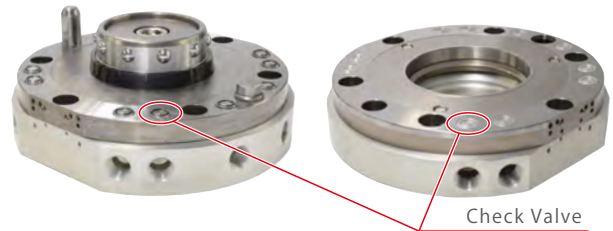

※1. It indicates holding force when air pressure is at 0MPa after connecting and may not fill the specification.

Master Cylinder SWR2300-MAF

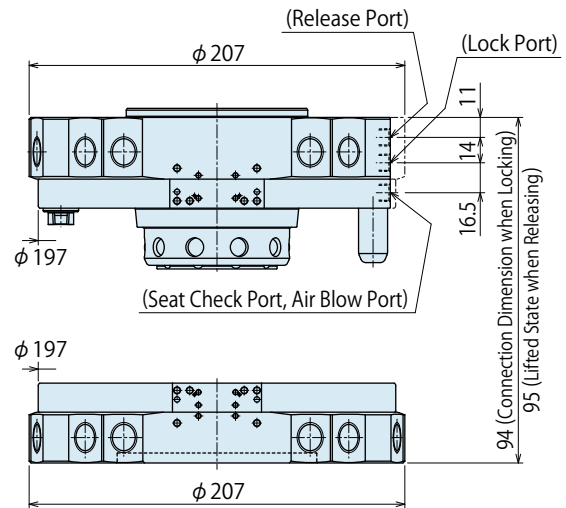
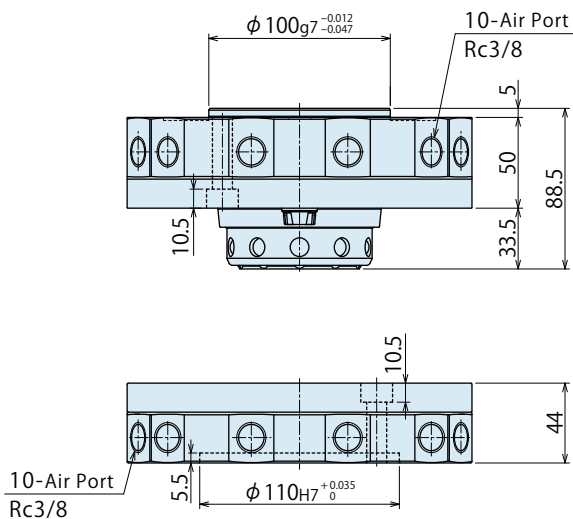

Tool Adapter SWR2300-T

KOSMEK

Harmony in Innovation

- HEAD OFFICE** 1-5, 2-Chome, Murotani, Nishi-ku, Kobe 651-2241
TEL.+81-78-991-5162 FAX.+81-78-991-8787
- BRANCH OFFICE (U.S.A.)** KOSMEK (U.S.A.) LTD.
650 Springer Drive, Lombard, IL 60148 USA
TEL. +1-630-620-7650 FAX. +1-630-620-9015
- MEXICO REPRESENTATIVE OFFICE** KOSMEK USA Mexico Office
Blvd Jurica la Campana 1040, B Colonia Punta Juriquilla Queretaro, QRO 76230 Mexico
TEL.+52-442-161-2347
- BRANCH OFFICE (EUROPE)** KOSMEK EUROPE GmbH
Schleppeplatz 2 9020 Klagenfurt am Wörthersee Austria
TEL.+43-463-287587 FAX.+43-463-287587-20
- BRANCH OFFICE (INDIA)** KOSMEK LTD - INDIA
F 203, Level-2, First Floor, Prestige Center Point,
Cunningham Road, Bangalore -560052 India
TEL.+91-9880561695
- THAILAND REPRESENTATIVE OFFICE** 67 Soi 58, RAMA 9 Rd., Suanluang, Suanluang, Bangkok 10250
TEL. +66-2-300-5132 FAX. +66-2-300-5133

- FOR FURTHER INFORMATION ON UNLISTED SPECIFICATIONS AND SIZES, PLEASE CALL US.
- SPECIFICATIONS IN THIS LEAFLET ARE SUBJECT TO CHANGE WITHOUT NOTICE.



<http://www.kosmek.com>