

New

High-Power Automation Pallet Clamp **PAT.**



Model WVG

Permanent Holding Force
Low Profile

High-Power Automation Pallet Clamp

Model WVG



Permanent Holding Force
Low Profile

Locating Repeatability : 0.08mm

100% Stainless Steel

PAT.

Available in three body sizes.

Clamping force is **4kN / 6kN / 10kN**

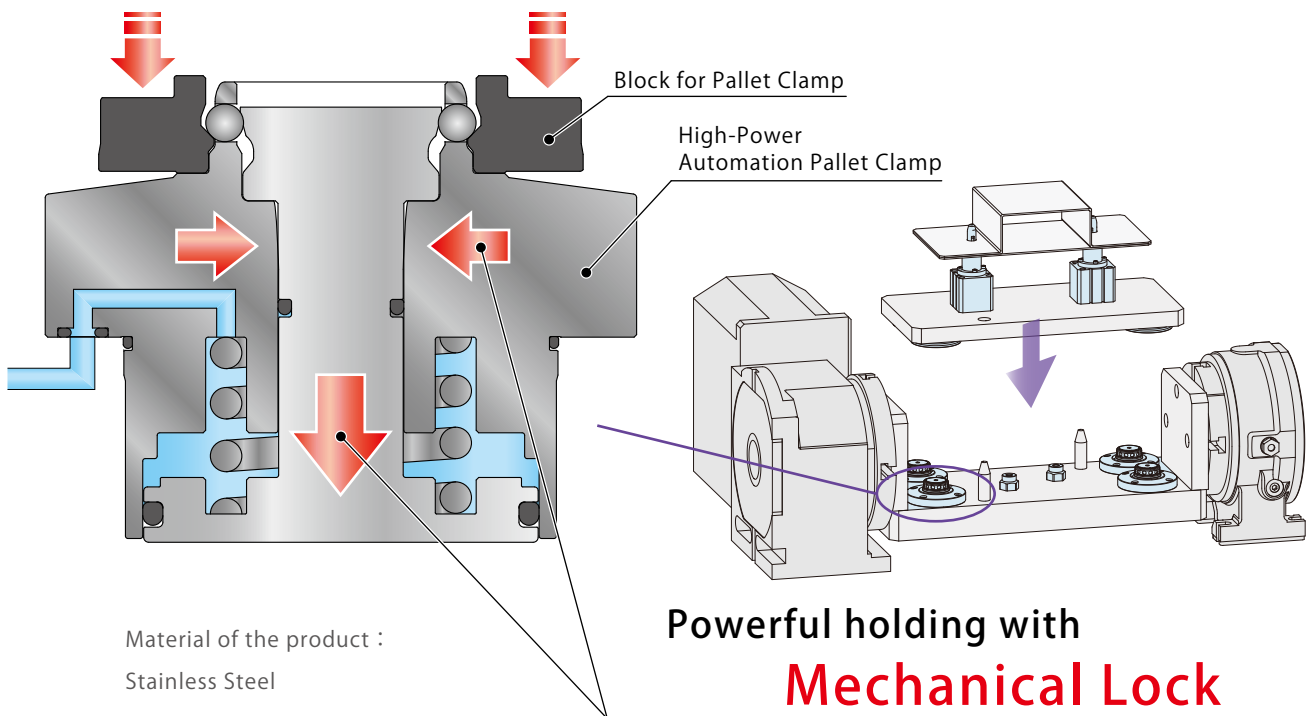

※ Clamping force varies depending on operating pressure.
※ This is a simplified drawing. Actual components are different.



Sensor Attachment

Model WVGT

Detects the lock action and the release action of the clamp with the use of an auto switch (prepared by customer).

Setup Improvement Enhances Productivity

High-Power Automation Pallet Clamp locates and clamps simultaneously. Fixture changeover becomes faster and easier, and equal clamping force and locating accuracy are ensured.

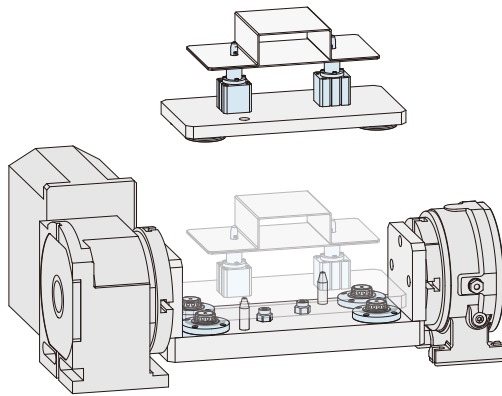

< Welding Fixture Setup >

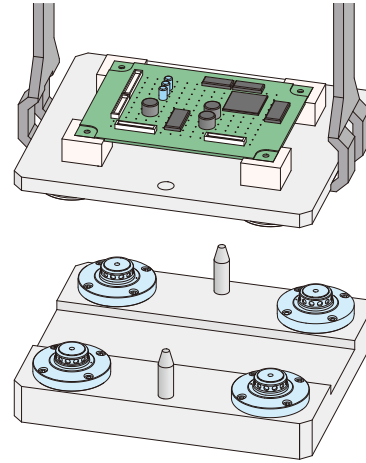

< Fixture Setup and Pallet Transfer of Automation Device >

● High Clamping Force (High Power)

Powerful clamping force with KOSMEK exclusive mechanical locking.

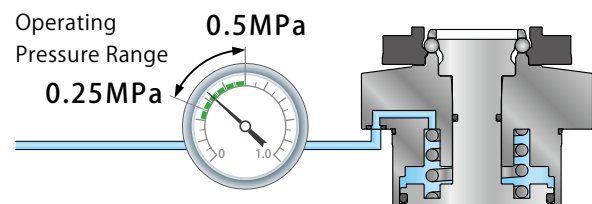

● High Safety : Fall Prevention

Mechanical locking is built in some steel ball parts. This enables powerful holding even when air pressure is at 0MPa. Powerful pulling capacity (holding force) prevents a pallet fall.

※ Please refer to "Clamping Force Curve" on P. 9 for pulling capacity (holding force).

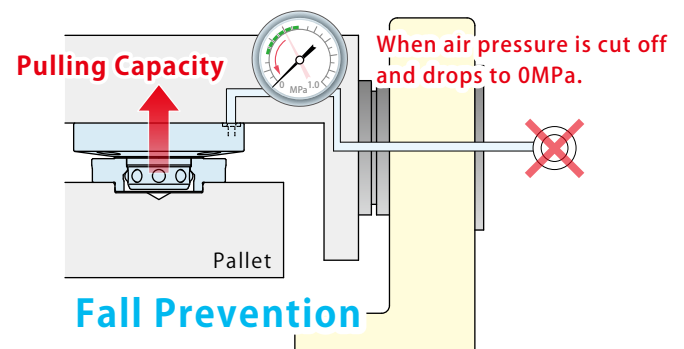

● Compact Body enables Smooth Loading

Fixture can be smaller with the compact clamp body. Also, the low clamping and locating part enables smooth loading/unloading.

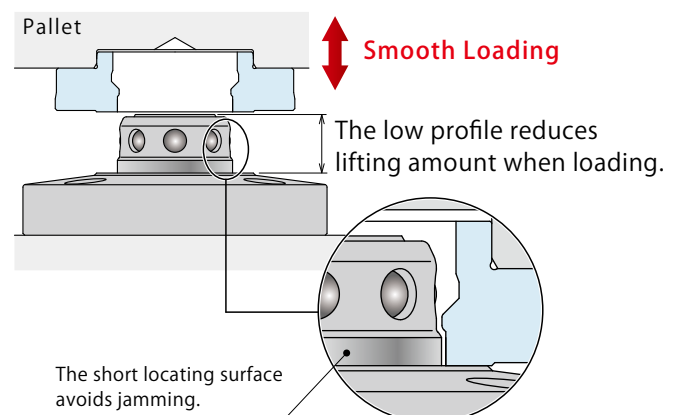

● 100% Stainless Steel

Function Description

※ Refer to P.7 for detailed action description.

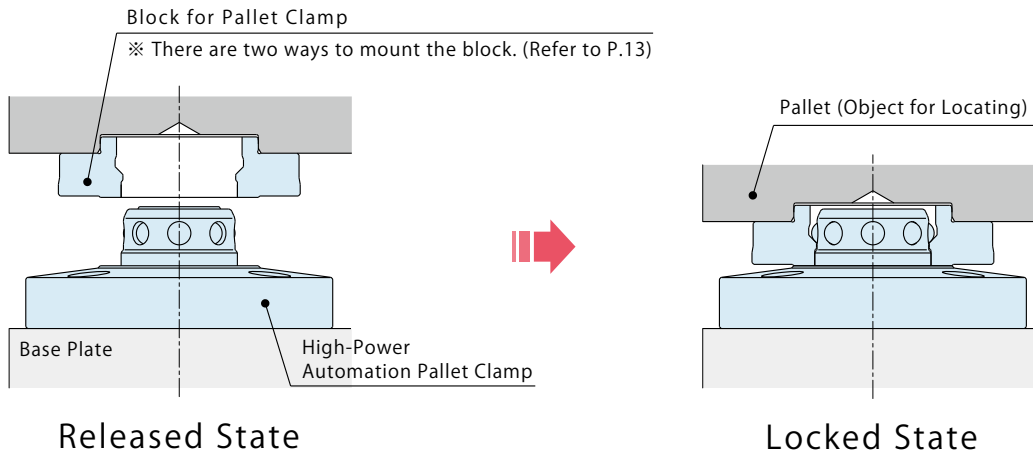

Locating Function

Locating repeatability is 0.08mm.
The clamp locates with the locating part in the drawing below.

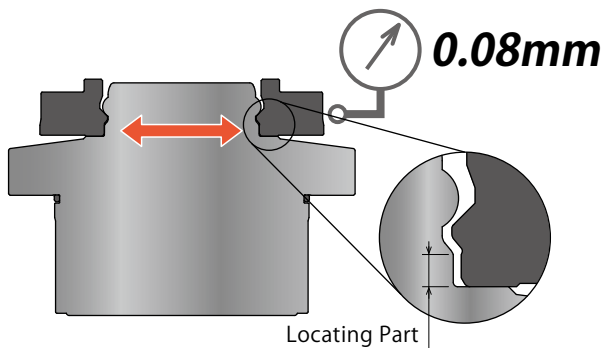

Clamping Function

Clamping force is 2.1kN ~ 9.5kN.
Powerful clamping with air pressure, mechanical locking and self-locking spring.

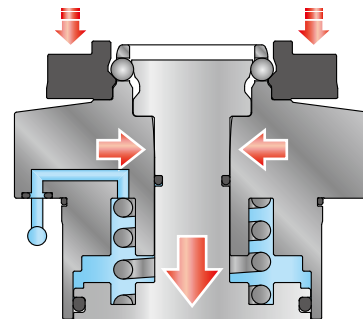

Self-Locking (Safety) Function (Maintains Clamping at 0MPa)

Even if air supply is cut off, the clamp will stay locked with self-locking spring and mechanical lock function of steel ball parts.

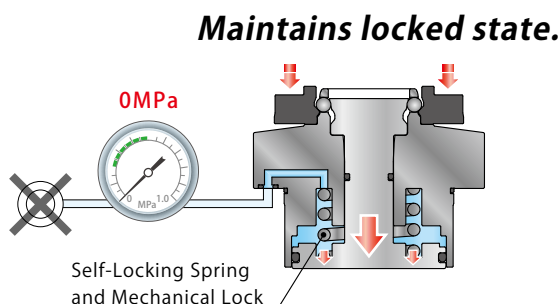



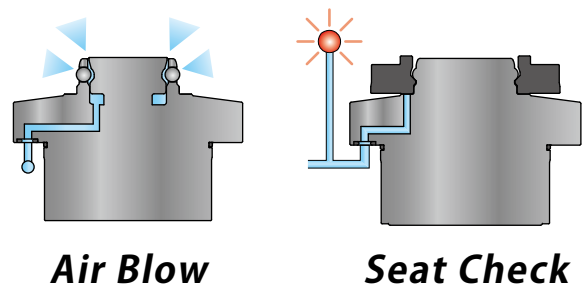

Air Blow Function and Seat Check Function

Contaminants are removed by air blow.
Air vent hole is provided on the seating surface, and seating confirmation is available with a gap sensor.

※ When using an optional Sensor Attachment (WVGT-T), the seat check function cannot be used.

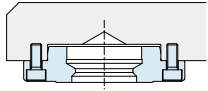
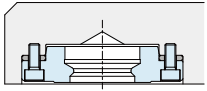

Products

	 Model WVG → P.11 Clamp	 Model WVGB → P.15 Block	
Classification	Double Acting Air Lock / Air Release Operating Pressure Range : 0.25 – 0.5MPa	Flange Mounting	Embedded Mounting
Features	<ul style="list-style-type: none"> • Strong Clamping Force with Mechanical Lock • Powerful Self-Locking with Mechanical Lock and Spring 	Simple machining for mounting hole 	Pallet can be directly placed on stocker. 
Accessory	 Model WVGT-T → P.13 Sensor Attachment	-	Level Adjustment Collar (only for embedded mounting) model VZ-VGC → P.15

Action Confirmation with Auto Switch

Sensor Attachment (model WVGT-T) enables action confirmation by using with an auto switch.

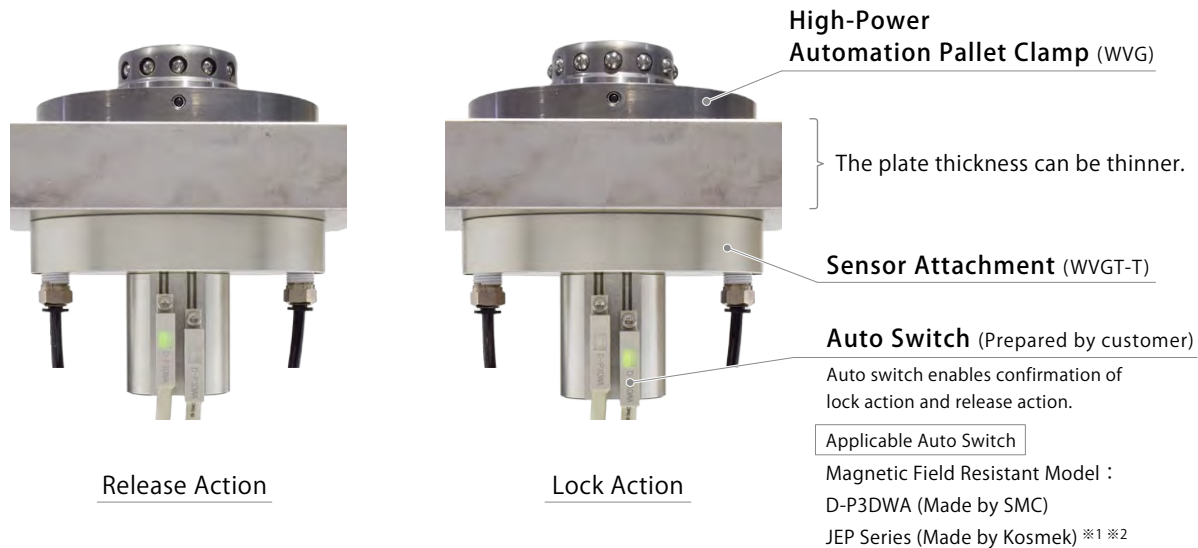

Notes :

- ※1. Refer to FA • Industrial Robot Related Products Complete Catalog (CATALOG No.FA0020□□-□□-GB) for the detailed specifications of JEP series.
- ※2. JEP series is not designed for magnetic field disturbance. Please use D-P3DWA (SMC) for an environment which generates a magnetic field disturbance.

1. When using an auto switch not made by Kosmek, check specifications of each manufacturer.
2. Depending on an installation position of an auto switch, it can be projected out from the bottom of the sensor attachment.

System References

When Using 4 Pallet Clamps

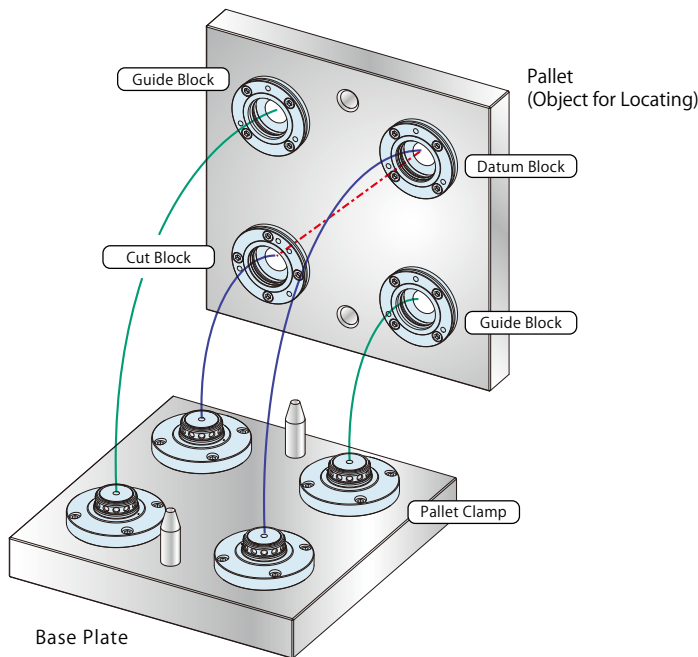

Products and Functions

Pallet Clamp

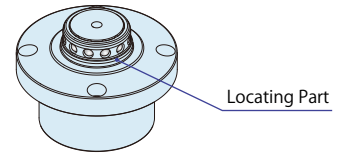

Datum Block

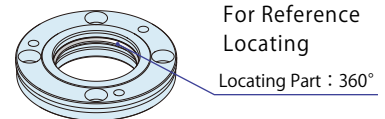

Cut Block



※ Only cut block requires attention in mounting phase. Please refer to P. 6 for detail.

When Using 2 Pallet Clamps

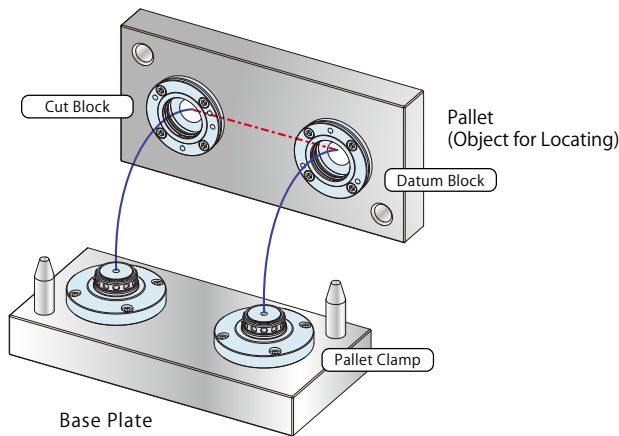

Guide Block

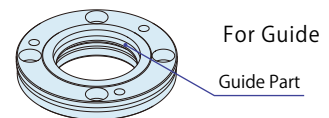

Circuit Reference

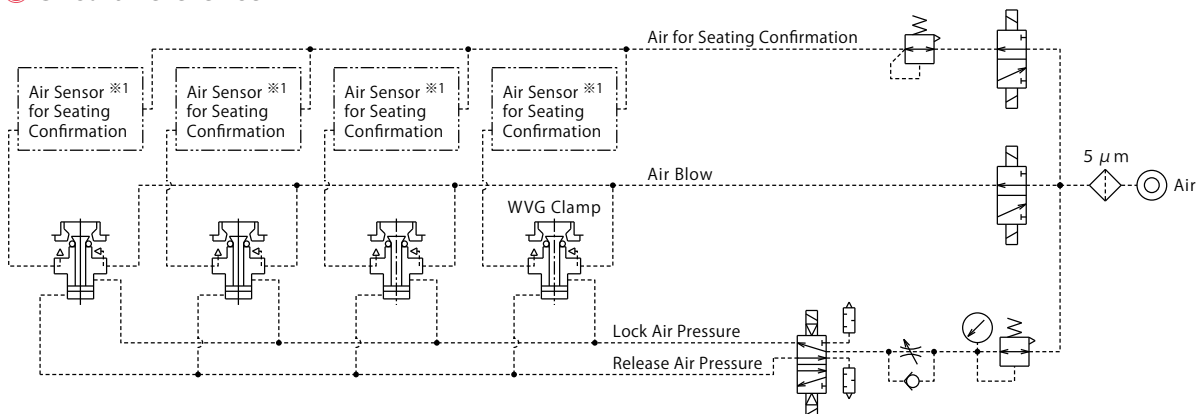

Notes: 1. Air blow passage should be $\phi 6$ or more for an effective air blow. Please supply filtered clean dry air.

※1. Please refer to the list on the right for recommended air sensors for seating confirmation.

Maker	SMC	CKD
Name	Air Catch Sensor	Gap Switch
Model No.	ISA3-G	GPS3-E

Configuration Sample of Pallets with Different Sizes

In case there are various sized pallets for one base plate, combine blocks for use.

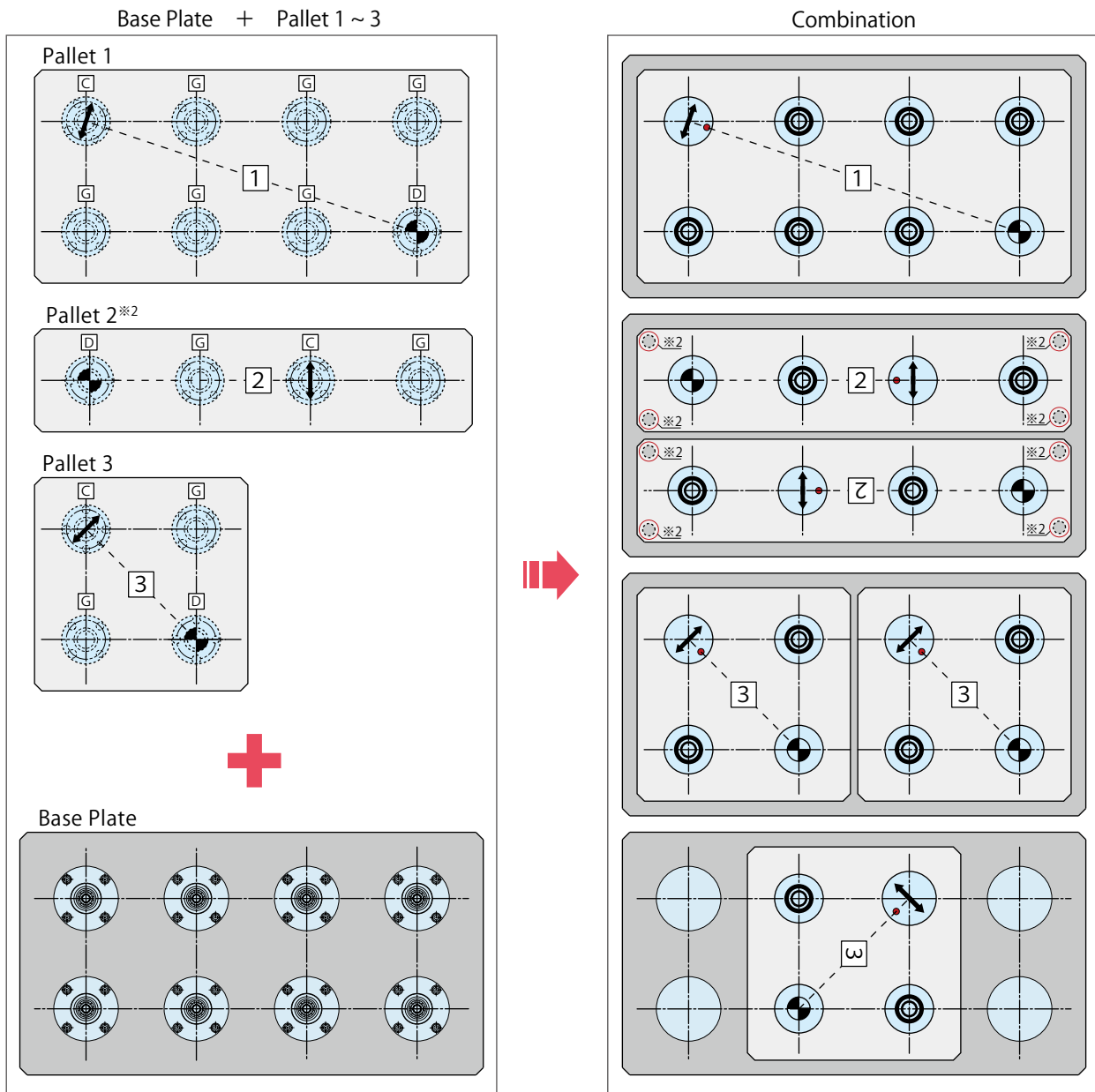

Combination of Clamp and Block

Installed to Base Plate	+	Installed to Pallet	⇒	Function(s) when Combined
	+	Datum Block	⇒	Clamping Function + Locating Function (Reference)
Pallet Clamp	+	Cut Block	⇒	Clamping Function + Locating Function (One Direction)
	+	Guide Block	⇒	Clamping Function

Notes :

- ※2. In case the clamp/block configuration is linear, it is recommended to provide additional supports for stability.
- ※3. The spring pin position is indicated. With the datum block as reference, unidirectional positioning is done via the cut block. The cut block positioning plane must be tangent to the datum block. (The spring pin is positioned on the line connecting the centers of the datum block and cut block.)

Action Description

- ※ This is a simplified drawing. Actual components are different.
- ※ Refer to P.14 for the cross section of sensor attachment.

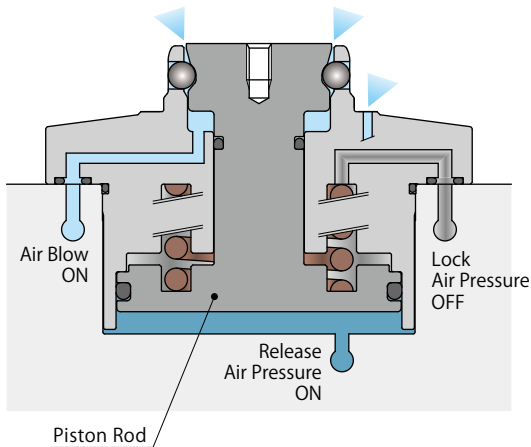

Before Loading the Pallet

- When release air pressure is ON and lock air pressure is OFF, the piston rod advances and the clamp is released.
- Air blow prevents debris contamination.

After Unloading the Pallet

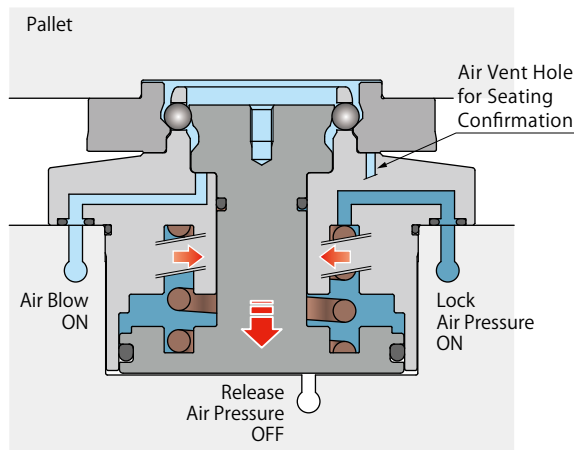

When Clamped

- When release air pressure is OFF and lock air pressure is ON, the air pressure, the spring force, and the mechanical lock lower the piston rod and the steel balls engage the block bringing it to the seating surface. (Stay clamped with mechanical lock.)
- The seating surface includes an air vent for seating confirmation (via air catch sensor).

When Clamped

【Caution】

For the use under the environment with coolant and cutting chips, it is recommended to use model WVS / model SWT that are equipped with contamination-preventing dust seal. This product (model WVG) has no dust seal, but only air blow function that prevents contamination.

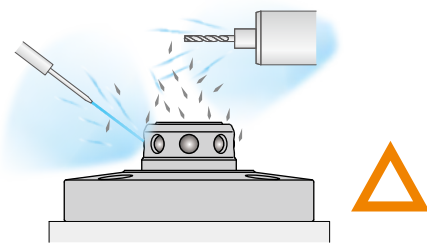

● Action Description during Loading/Unloading

1. With air pressure released, load the pallet within the allowable offset.
Air pressure must be continuously supplied to the air blow port.

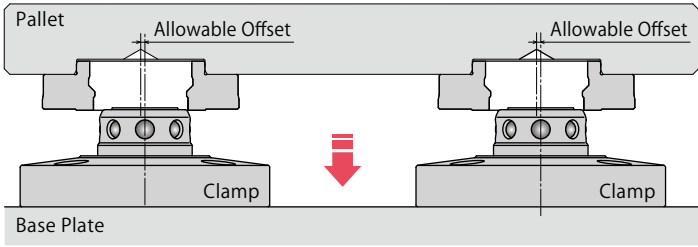

2. When lowering the pallet, roughly position it by using A part.

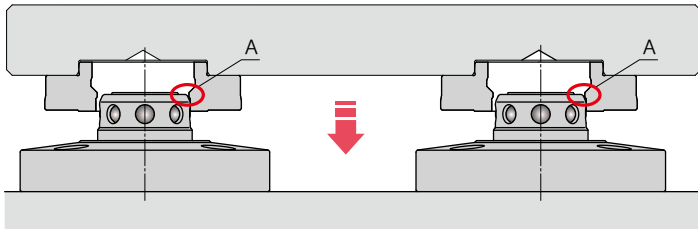

3. When release air pressure is OFF and lock air pressure is ON, the block is pressed onto the seating surface with air pressure, spring force and mechanical lock.

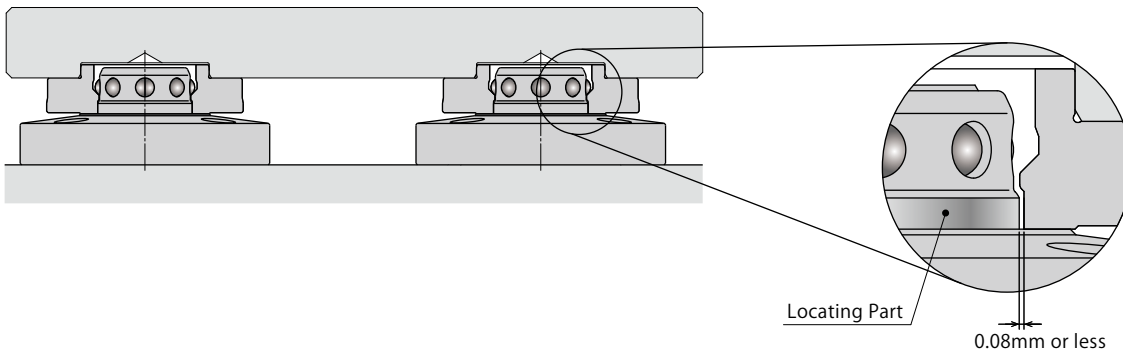

A fixture pallet must be level when loaded or removed from pallet clamps. The clamps and blocks will be damaged if the pallet is tilted when loading/unloading (especially when loading). Provide guide pins (rough guide) to keep the pallet level during loading and unloading.

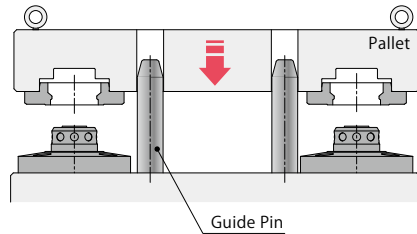
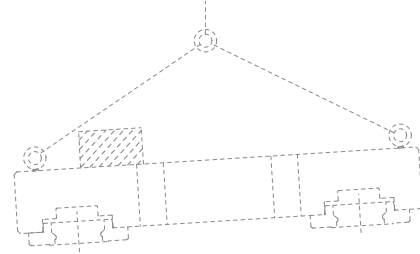

【Caution】

Do not apply an impact during loading/unloading.
Failure to do so leads to damage of the product and decrease in locating accuracy.

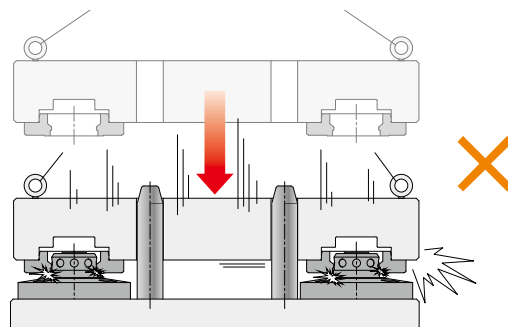

● Model No. Indication (Pallet Clamp)

WVG 0 06 0 - M

1 **2**



1 Clamping Force

- 04** : Clamping Force 3.7kN (Air Pressure 0.5MPa)
- 06** : Clamping Force 5.8kN (Air Pressure 0.5MPa)
- 10** : Clamping Force 9.5kN (Air Pressure 0.5MPa)
- ※ Refer to the clamping force curve below for detail.

2 Design No.

0 : Revision Number

● Combination of Clamp and Block

Clamp model	Block model	Function
WVG-M	WVGB-D (Datum Block)	Clamping + Reference Locating
	WVGB-C (Cut Block)	Clamping + One Direction Locating
	WVGB-G (Guide Block)	Clamping

● Clamping Force Curve

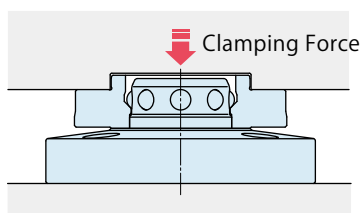

(Ex.) In case of WVG0060-M
when supply air pressure is 0.4MPa,
clamping force becomes about 4.8kN.

Model No.		WVG0040-M	WVG0060-M	WVG0100-M
Clamping Force	Air Pressure 0.5 MPa	3.7	5.8	9.5
	Air Pressure 0.45 MPa	3.4	5.3	8.6
	Air Pressure 0.4 MPa	3.1	4.8	7.8
	Air Pressure 0.35 MPa	2.7	4.3	6.9
	Air Pressure 0.3 MPa	2.4	3.8	6.0
	Air Pressure 0.25 MPa	2.1	3.3	5.2
Pulling Capacity (Holding Force) at 0 MPa ※1		4	6	10
Operating Pressure Range		0.25 ~ 0.5		

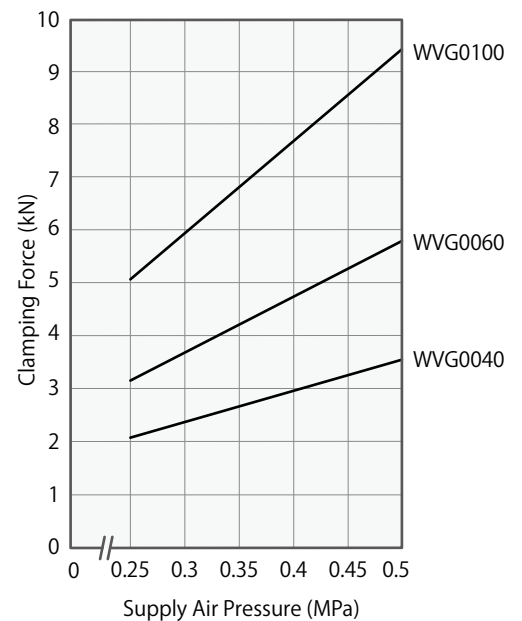

Notes :

1. This graph shows the value for single clamp.

※1. It shows "Pulling Capacity (Holding Force)" at 0MPa air pressure and it is not a clamping force.

● Model No. Indication (Block)



WVGB 06 0 - D

1
2
3

1 Applicable Clamp Model

- 04 : WVG0040-M
- 06 : WVG0060-M
- 10 : WVG0100-M

2 Design No.

- 0 : Revision Number

3 Functions

- D** : Datum Block (for Reference Locating)
- C** : Cut Block (for One Direction Locating)
- G** : Guide Block (for Clamping)

Block (WVGB) is applicable for both flange mounting and embedded mounting.

Flange Mounting

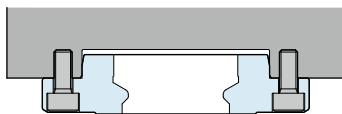

Embedded Mounting

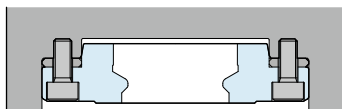

● Model No. Indication (Sensor Attachment)



WVGT 06 0 - T

1
2

1 Applicable Clamp Model

- 04 : WVG0040-M
- 06 : WVG0060-M
- 10 : WVG0100-M

2 Design No.

- 0 : Revision Number

● Model No. Indication (Level Adjustment Collar)

- ※ This product is required in case of embedded mounting method.
- ※ Material : Equal to S45C



VZ 0 06 0 - VGC

1
2

1 Applicable WVGB Block Model

- 04: WVGB040-□
- 06: WVGB060-□
- 10: WVGB100-□

2 Design No.

- 0 : Revision Number

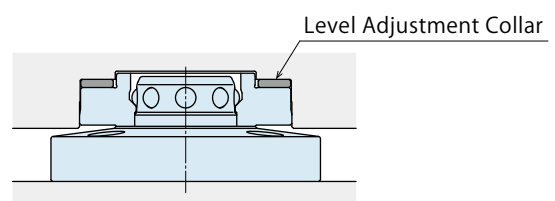

External Dimensions

※ This drawing shows the released state of WVG (when supplying release air pressure).

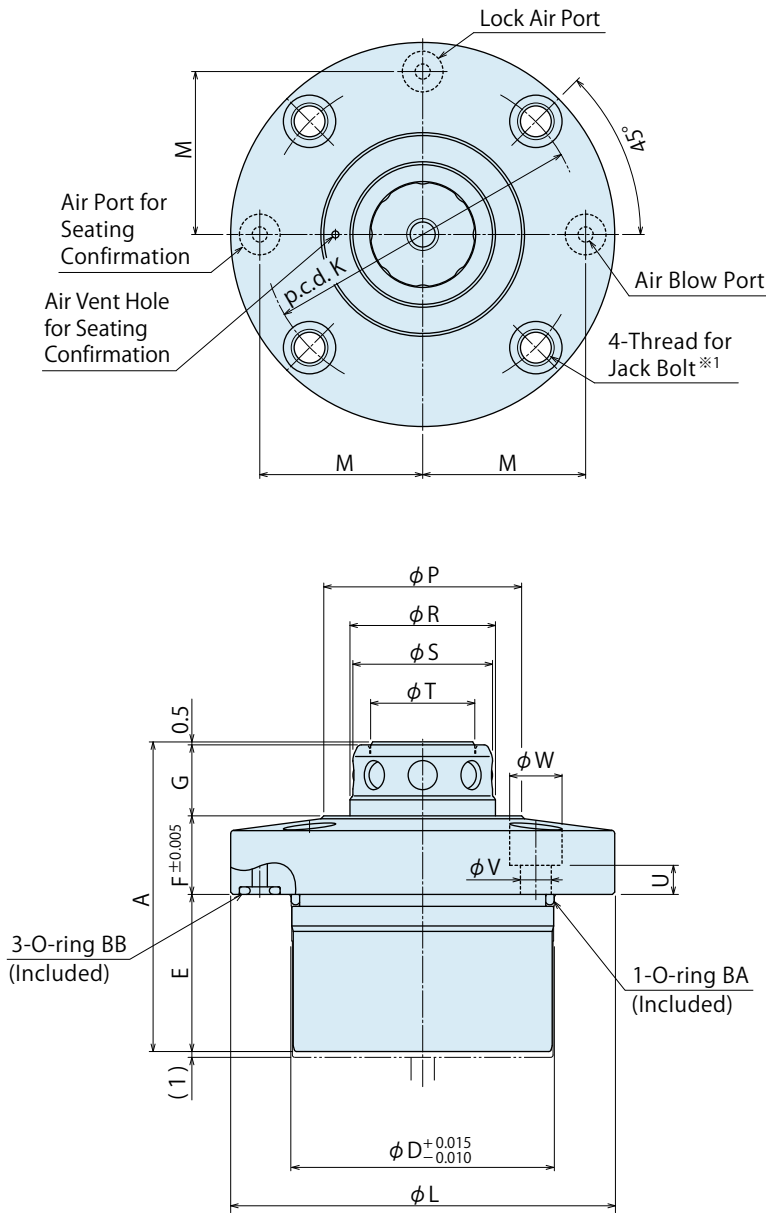

Notes :

※ 1. The thread for jack bolt is used when removing the clamp.
(See P.21 for usage.)

Machining Dimensions of Mounting Area

※ Refer to P.13 for machining dimensions when using Sensor Attachment WVGT□-T.

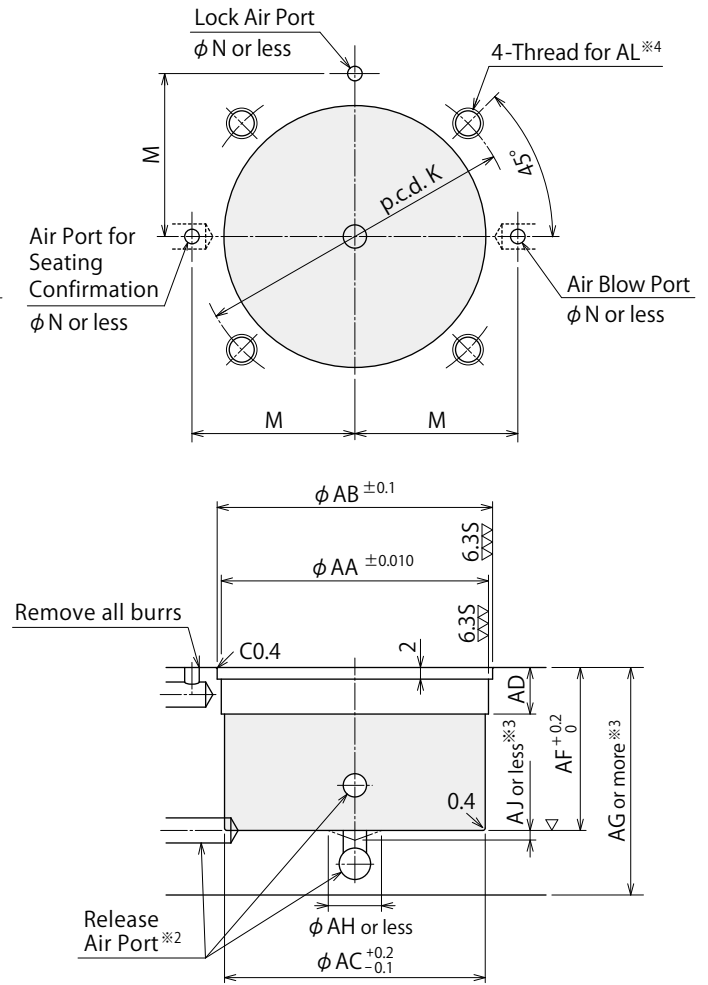

Notes :

1. Make sure no burrs are on or around the hole intersection.
- ※ 2. Release air port should be machined within \square range.
- ※ 3. The base thickness (AG) and remaining depth after boring (AJ) are reference values when the base material is S50C.
- ※ 4. Mounting bolts are not provided. Please prepare them separately.

Distance Accuracy of Each Clamp

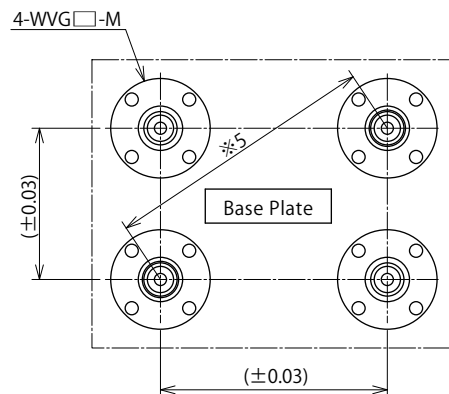

Note :

※ 5. Please make sure the distance accuracy of each datum clamp is better than ± 0.03 mm.

Specifications

Model		WVG0040-M	WVG0060-M	WVG0100-M
Locating Repeatability	mm	0.08		
Clamping Force		Refer to P.9		
Pulling Capacity (Holding Force) at 0MPa		Refer to P.9		
Full Stroke	mm	3.8	3.8	4.4
Allowable Offset when fixture pallet is set	mm	1.0	1.0	1.5
Cylinder Capacity ※6	Lock	8.8	14.1	26.8
	Release	9.3	14.7	28.1
Max. Operating Pressure	MPa	0.5		
Min. Operating Pressure	MPa	0.25		
Withstanding Pressure	MPa	0.75		
Air Blow Pressure	MPa	0.4 ~ 0.5		
Operating Temperature	°C	0 ~ 70		
Usable Fluid		Dry Air		
Weight ※6	kg	0.6	0.8	1.4

Note :

※6. It indicates the value of single clamp.

External Dimensions and Machining Dimensions for Mounting (mm)

Model No.	WVG0040-M	WVG0060-M	WVG0100-M
A	53.2	54.2	63
D	45	55	69
E	27	28	32
F	13.5	13.5	16
G	12.2	12.2	14.5
K	55	65	81
L	66	76	94
M	28	33	41
N	2.5	2.5	3
P	34	43	52
R	25	34	42
S	24	32	40
T	17.9	25.9	32.8
U	5	5	6
V	5.3	5.3	6.8
W	9	9	11
AA	45	55	69
AB	45.2	55.2	69.2
AC	44.8	54.8	68.8
AD	8	8	9
AF	28	29	33
AG	35	35	40
AH	9	9	14
AJ	2.5	2.5	2.5
AL	M5×0.8	M5×0.8	M6×1
1-O-ring BA	AS568-030(70)	AS568-033(70)	AS568-037(70)
3-O-ring BB	AS568-007(70)	AS568-007(70)	1AP5
Thread for Jack Bolt	M6×1	M6×1	M8×1.25

External Dimensions

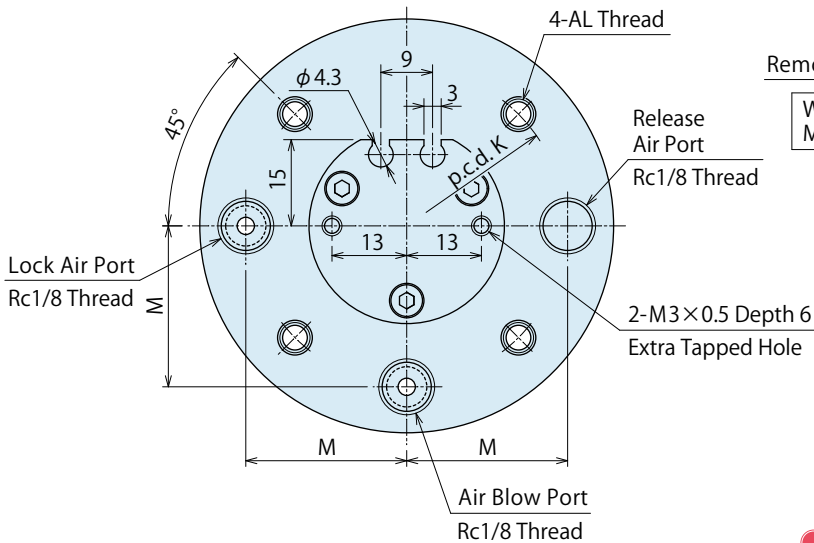
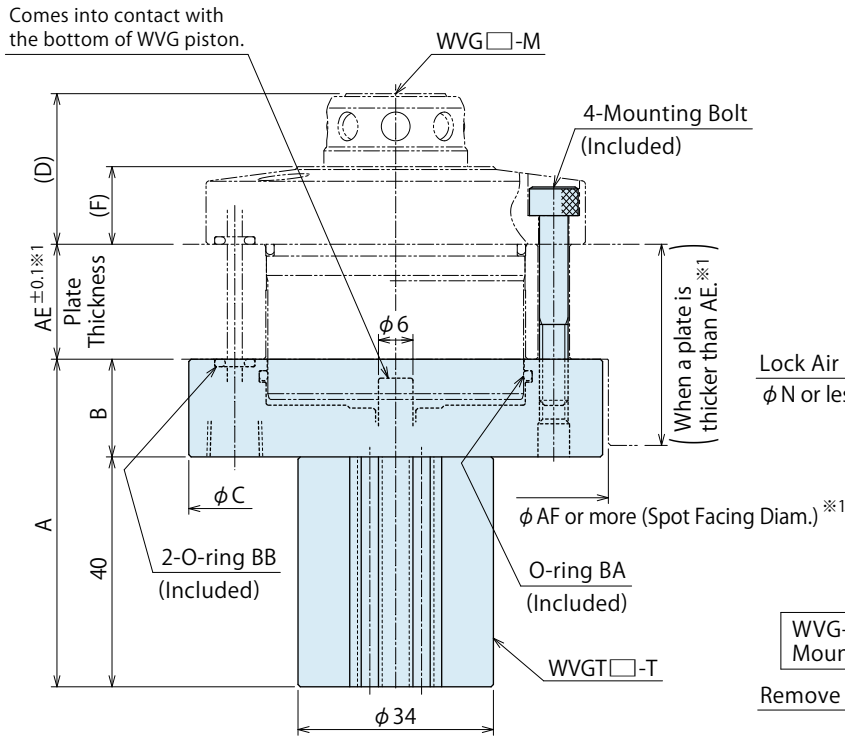

Notes :

1. Not equipped with a seating check port.
2. Please use an anti-magnetic field auto switch for an environment which generates a magnetic field disturbance.
Recommended Auto Switch Model No. : D-P3DWA (Made by SMC)

Machining Dimensions of WVGT Clamp Mounting Area

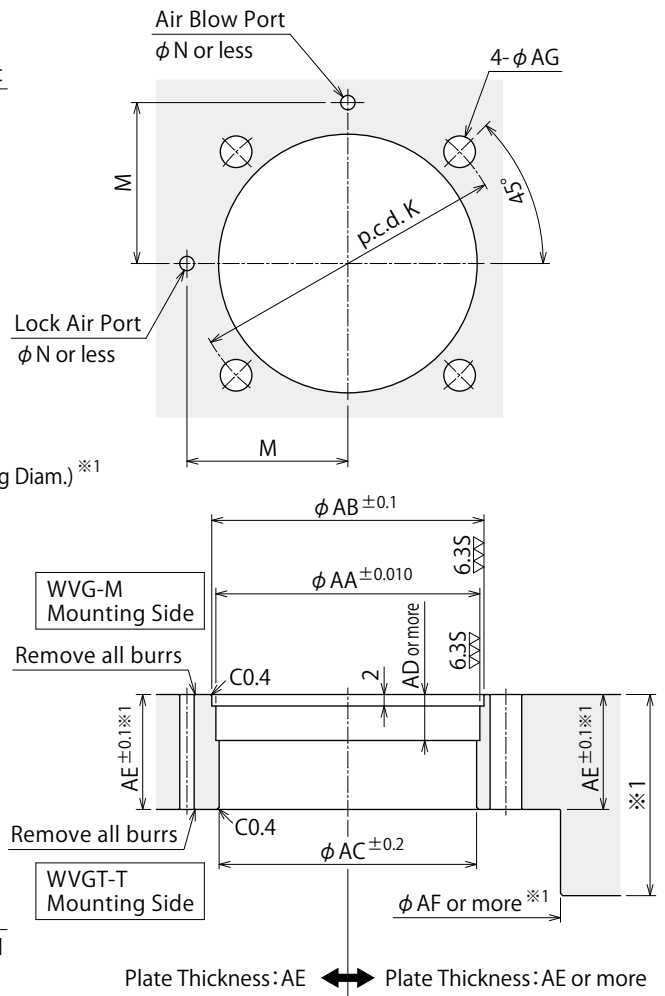

Note :

- *1. When a plate is thicker than AE, prepare the spot facing diameter more than φ AF.

Distance Accuracy of Each Clamp

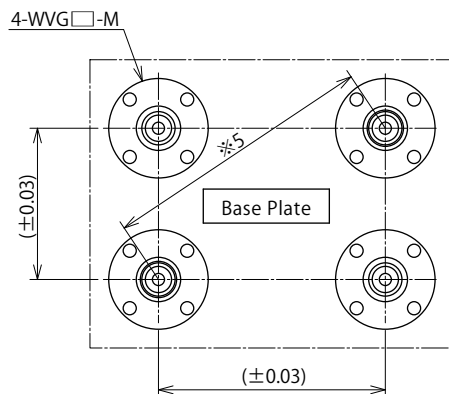

Note :

- *5. Please make sure the distance accuracy of each datum clamp is better than ±0.03mm.

External Dimensions and Machining Dimensions for Mounting

(mm)

Model No.	WVGT040-T	WVGT060-T	WVGT100-T
Applicable Clamp	WVG0040-M	WVG0060-M	WVG0100-M
A	57	58	57
B	17	18	17
C	72	82	98
D	26.2	26.2	31
F	13.5	13.5	16
K	55	65	81
M	28	33	41
N	2.5	2.5	3
AA	45	55	69
AB	45.2	55.2	69.2
AC	44.8	54.8	68.8
AD	8	8	9
AE	20	20	25
AF	74	84	100
AG	5.5	5.5	6.8
AL	M5×0.8	M5×0.8	M6×1
O-ring BA	AS568-032(70)	AS568-035(70)	AS568-039(70)
O-ring BB	AS568-007(70)	AS568-007(70)	1AP5
Mounting Bolt (Material:SCM Strength Class:12.9)	M5×0.8×35	M5×0.8×35	M6×1×40

Installation Procedure

Follow the installation drawing on the right.
 (Put the base plate between WVGT and WVG)
 Use the mounting bolt (included) and install them parallel to each other. Also, check each port position before installation.
 Please follow the below tightening torque of the mounting bolt.

Sensor Attachment Model No.	Mounting Bolt Size	Mounting Bolt Qty.	Tightening Torque (N·m)
WVGT040-T	M5×0.8	4	6.3
WVGT060-T	M5×0.8	4	6.3
WVGT100-T	M6×1	4	10

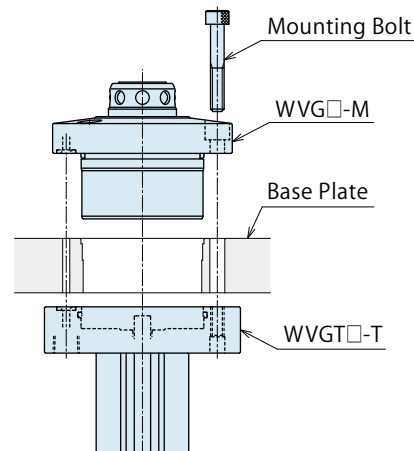

Cross Section

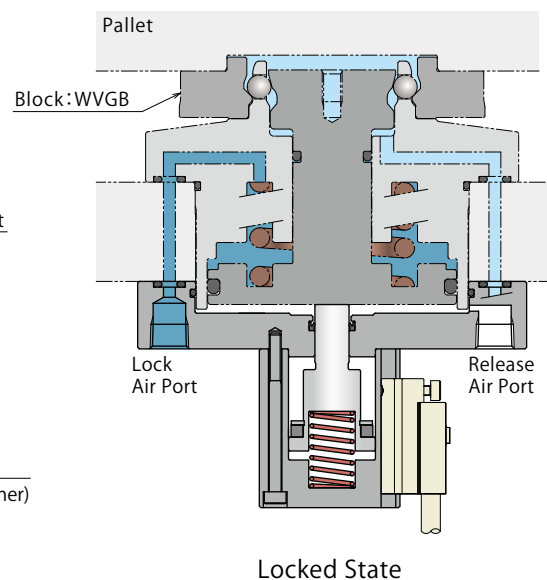
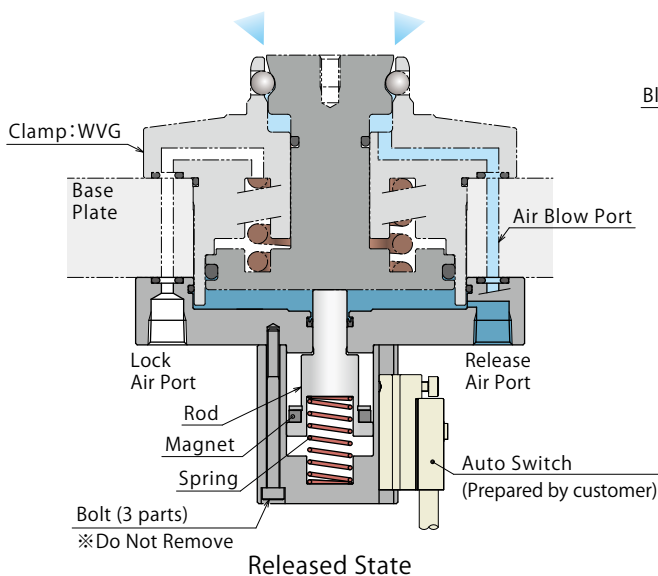

External Dimensions

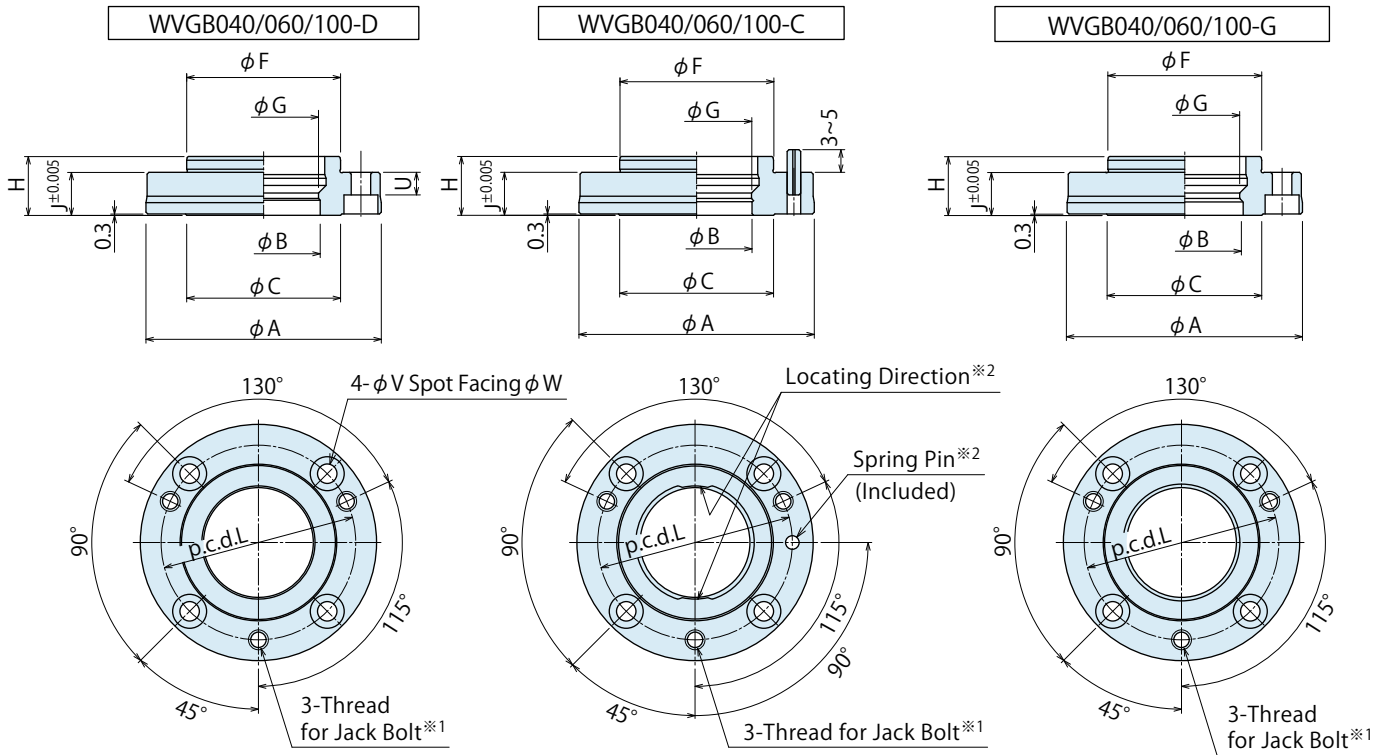

Notes :

- ※1. The thread for jack bolt is used when removing WVGB block.
- ※2. The spring pin is used for phasing of WVGB-C locating direction.

Machining Dimensions of Mounting Area

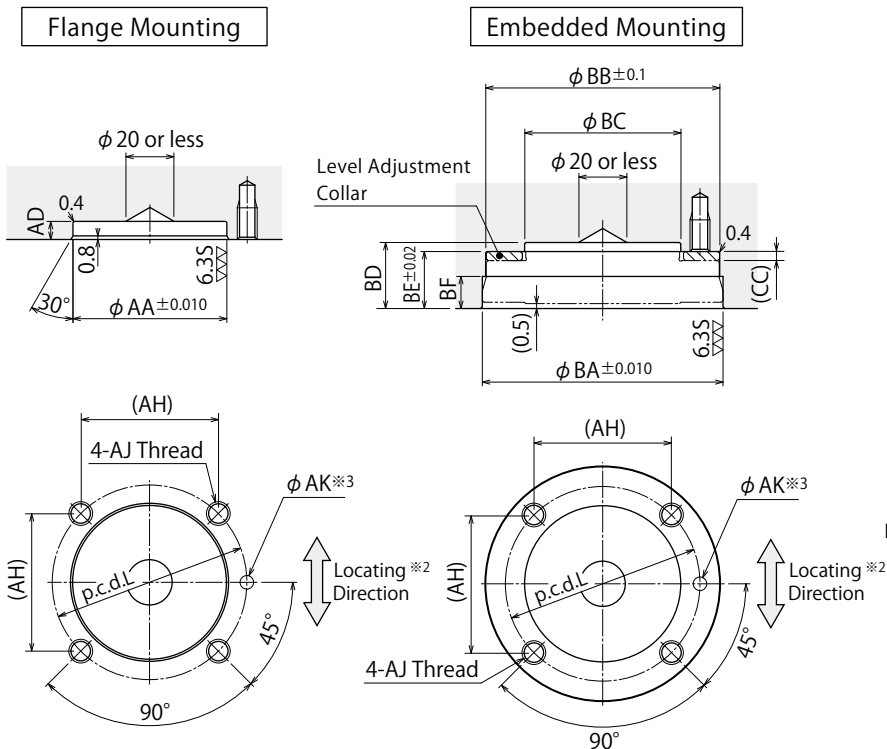

Notes :

1. This embedded mounting drawing shows when the clearance between the seating surface of WVGB block and the bottom surface of a pallet is 0.5mm by using the level adjustment collar.
2. Mounting bolts are not provided. Please prepare them separately.
- ※3. phi AK hole is used for phasing of WVGB-C locating direction. Please make sure phi AK hole is at the line connecting the centers of WVGB-D and WVGB-C. This machining is only necessary for WVGB-C.

Dimensions of Level Adjustment Collar

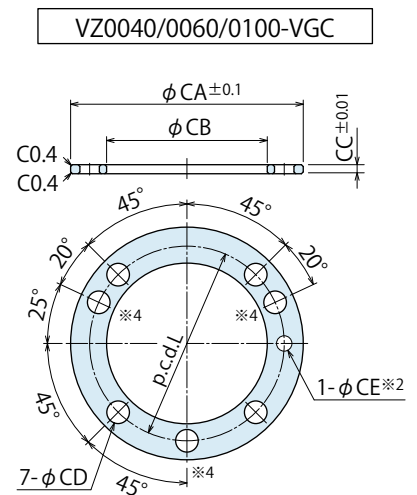

Notes :

1. Refer to the drawing above when preparing the level adjustment collar by yourself.
- ※4. The thread (3 parts) is for jack bolt. Align them with the phase of thread for jack bolt of WVGB block.

※ Mounting Drawing of Level Adjustment Collar

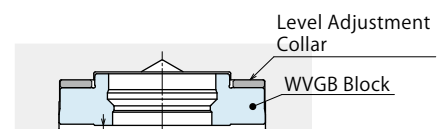

- ※5. Clearance between the seating surface of WVGB block and the bottom surface of the pallet.

● Mounting Distance Accuracy and WVGB-C Phase ● Connected State Dimensions

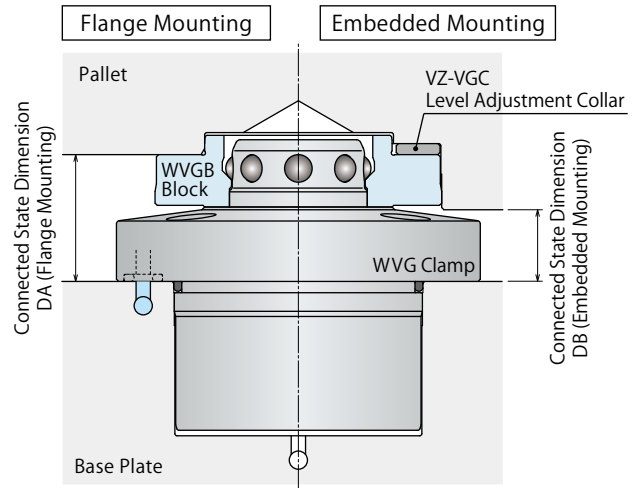
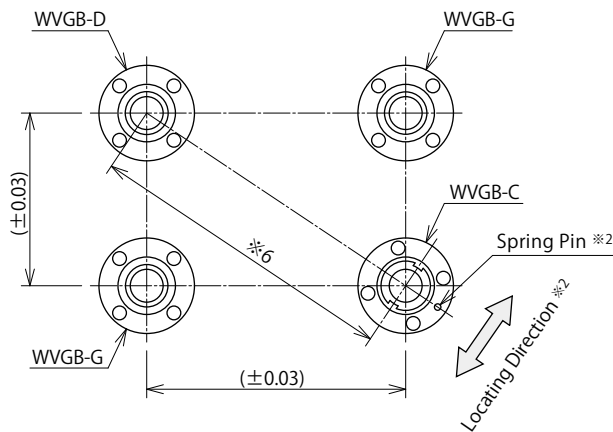

Note :

※6. Distance accuracy of the block should be within ± 0.03 mm between the blocks with the longest distance.

● External Dimensions and Machining Dimensions for Mounting

(mm)

Model No.	WVGB040-D WVGB040-C	WVGB040-G	WVGB060-D WVGB060-C	WVGB060-G	WVGB100-D WVGB100-C	WVGB100-G
A	52 ^{+0.015} _{-0.010}	52g7 ^{-0.010} _{-0.040}	64 ^{+0.015} _{-0.010}	64g7 ^{-0.010} _{-0.040}	77 ^{+0.015} _{-0.010}	77g7 ^{-0.010} _{-0.040}
B	25	25.8	34	34.8	42	42.8
C	34		43		52	
F	34 ^{+0.015} _{-0.010}	34g7 ^{-0.009} _{-0.034}	43 ^{+0.015} _{-0.010}	43g7 ^{-0.009} _{-0.034}	53 ^{+0.015} _{-0.010}	53g7 ^{-0.010} _{-0.040}
G	24.25		32.25		40.3	
H	13		13		15.5	
J	10		10		12	
L	43		53		64	
U	5.5		4.5		5	
V	4.3		5.5		6.8	
W	7.5		9		11	
Thread for Jack Bolt	M4×0.7		M5×0.8		M6×1	
Spring Pin ※7	φ3×10	-	φ4×10	-	φ4×10	-
AA※8	34		43		53	
AD	3.5		3.5		4	
(AH)	30.41		37.48		45.25	
AJ	M4×0.7		M5×0.8		M6×1	
AK	φ3.4 Depth 5	-	φ4.5 Depth 5	-	φ4.5 Depth 5	-
BA※8	52		64		77	
BB	51.7		63.7		76.7	
BC	34.5		43.5		53.5	
BD	14		14		16.5	
BE	12.5		12.5		15.5	
BF	6.5		6.5		8	
Applicable Clamp	WVG0040-M		WVG0060-M		WVG0100-M	
Connected State Dimension	DA (Flange Mounting)	23.5		28		
	DB (Embedded Mounting)	13		15.5		
Weight	0.15kg		0.2kg		0.35kg	

Model No.	VZ0040-VGC	VZ0060-VGC	VZ0100-VGC
CA	51.4	63.4	76.4
CB	35.5	44.5	54.5
CC	2	2	3
CD	5	6	7.5
CE	3.4	4.5	4.5
Weight	0.02kg	0.025kg	0.05kg

Notes :

※ 7. The spring pin is included in WVGB-C only.

※ 8. Pallet with low rigidity (thin pallet or pallet made of aluminum etc.) may be deformed when mounting WVGB block.

In this case, tolerance of mounting hole machining dimension ± 0.010 should be close to $+0.010$ (the upper limit of the tolerance).

● Related Products

■ Auto Coupler (Oil/Air/Coolant) model JVC/JVD, JVE/JVF

Coupler with ultra-small connecting stroke for automation.
Compact body can be set into a narrow space.

→ Refer to our website and catalog for detailed specifications.



Flange Mounting

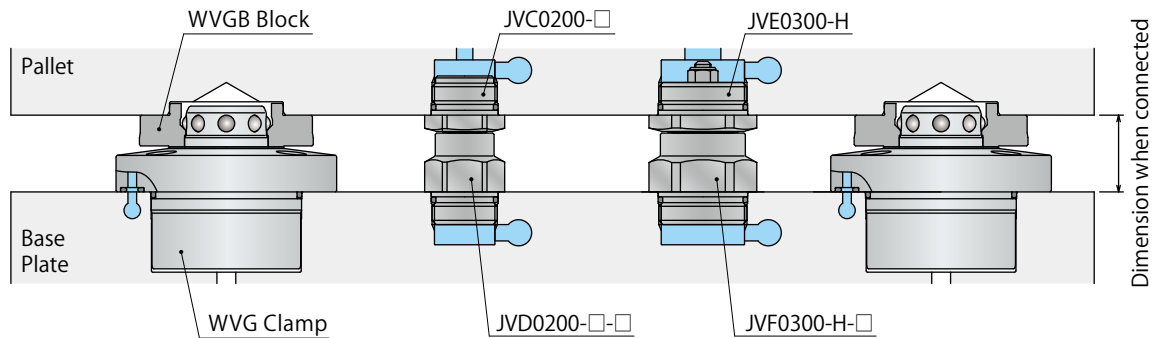

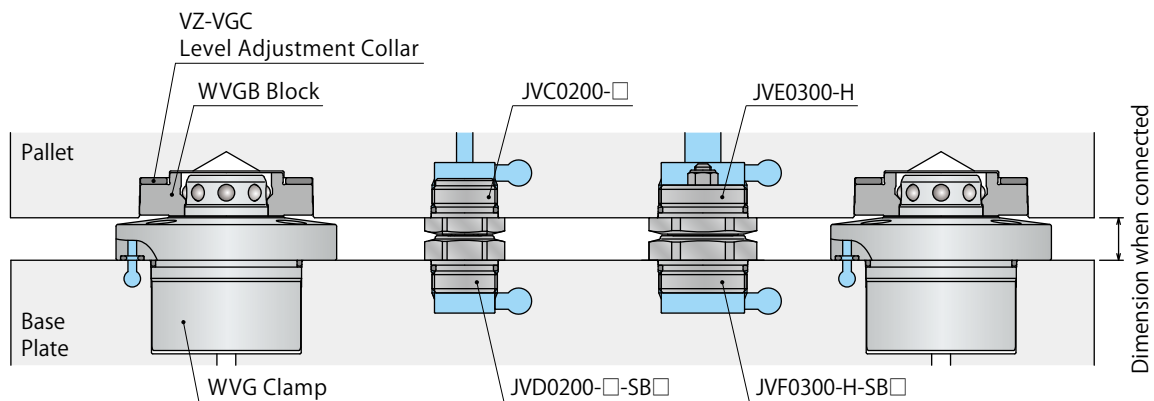

Clamp Model No.		WVG0040-M	WVG0060-M	WVG0100-M
Block Model No.		WVGB040-□	WVGB060-□	WVGB100-□
Dimension when connected	mm	23.5		28
JVC/JVD Applicable Model (Min. Passage Area : 12.6 mm ²)	Base Side (JVD)	JVD0200-□-SJ06		JVD0200-□-GB10
	Pallet Side (JVC)	JVC0200-□		JVC0200-□
JVE/JVF Applicable Model (Min. Passage Area : 29.0 mm ²)	Base Side (JVF)	JVF0300-H-SJ06		JVF0300-H-GB10
	Pallet Side (JVE)	JVE0300-H		JVE0300-H

Embedded Mounting



Clamp Model No.		WVG0040-M	WVG0060-M	WVG0100-M
Block Model No.		WVGB040-□	WVGB060-□	WVGB100-□
Dimension when connected	mm	13		15.5
JVC/JVD Applicable Model (Min. Passage Area : 12.6 mm ²)	Base Side (JVD)	JVD0200-□-SB06		JVD0200-□-SB10
	Pallet Side (JVC)	JVC0200-□		JVC0200-□
JVE/JVF Applicable Model (Min. Passage Area : 29.0 mm ²)	Base Side (JVF)	JVF0300-H-SB06		JVF0300-H-SB10
	Pallet Side (JVE)	JVE0300-H		JVE0300-H

● Models

		Operating Pressure Range	Minimum Passage Area	Usable Fluid
Model JVC/JVD		7MPa or less	12.6mm ²	<div style="display: flex; flex-direction: column; align-items: center;"> <div style="background-color: #00AEEF; color: white; padding: 5px; margin-bottom: 5px;">Air</div> <div style="background-color: #E91E63; color: white; padding: 5px; margin-bottom: 5px;">General Hyd. Oil</div> <div style="background-color: #FF9800; color: white; padding: 5px;">Coolant <small>(for -H option)</small></div> </div>
Model JVE/JVF		1MPa or less	29.0mm ²	<div style="display: flex; flex-direction: column; align-items: center;"> <div style="background-color: #00AEEF; color: white; padding: 5px; margin-bottom: 5px;">Air</div> <div style="background-color: #FF9800; color: white; padding: 5px;">Coolant</div> </div>

● Cautions for Usage

When using WVG with Auto Coupler (JVC/JVD/JVE/JVF), please check the caution on P.20 "6) Using with Auto Coupler (JVC/JVD/JVE/JVF)" .

Cautions

Notes for Design

- 1) Check Specifications
 - Please use each product according to the specifications.
- 2) Notes for Circuit Design
 - Ensure there is no possibility of supplying air pressure to the lock port and the release port simultaneously. Improper circuit design may lead to malfunctions and damages.
 - Air blow passage should be $\phi 6$ or more for an effective air blow.

3) When Using a Pallet in Vertical Position

- When setting a workpiece or a fixture plate, make sure it is in proper proximity and square to the clamps. If it is locked out of position, the clamps may be damaged.

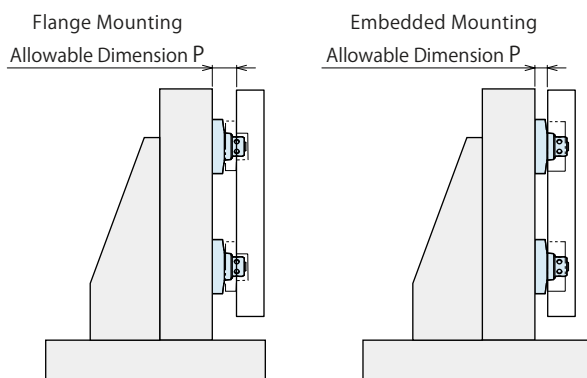

Allowable Dimension P (mm)			
Model No.	WVG0040	WVG0060	WVG0100
Flange Mounting	24	24	29
Embedded Mounting	14	14	16.5

Dimension of embedded mounting: In case the clearance between the seating surface of WVGB block and the bottom surface of a pallet is 0.5mm.

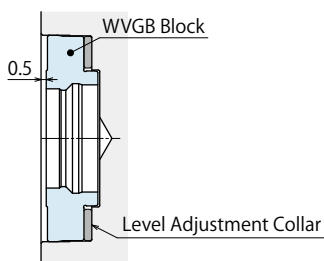

- As a workpiece/fixture plate may fall down when releasing, it is recommended to set up the latching mechanism to prevent a fall.

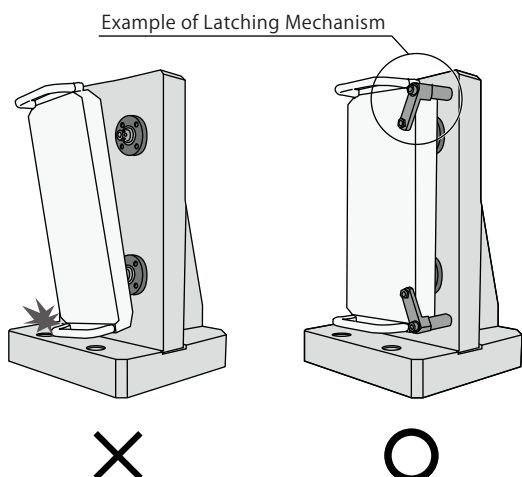

- When a pallet is used in vertical position (hanging on the wall), the locating parts tend to wear out. Please Check the locating accuracy on a regular basis, and replace the product in case the locating accuracy exceeds the allowable range.
- When a pallet is in vertical position, make sure the weight of the workpiece/fixture pallet is 10% of the clamping force.
- 4) Setting of Seating
 - In case the clamp/block configuration is linear, it is recommended to provide additional supports for stability.

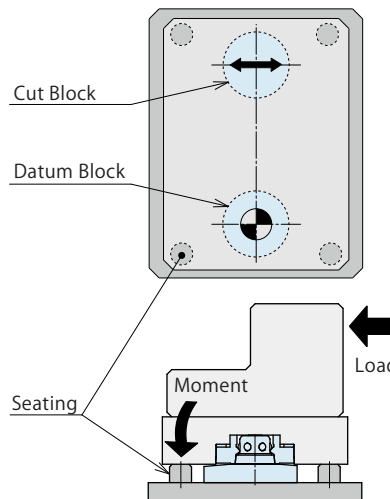

5) Setting of Rough Guide

- If the position of the pallet during loading is outside the clamp allowable offset, the clamp may contact the seating surface and the taper surface of the block (WVGB-D) causing damage to the product and decrease of the locating accuracy. It is recommended to use rough guides to load the pallet within the allowable offset.

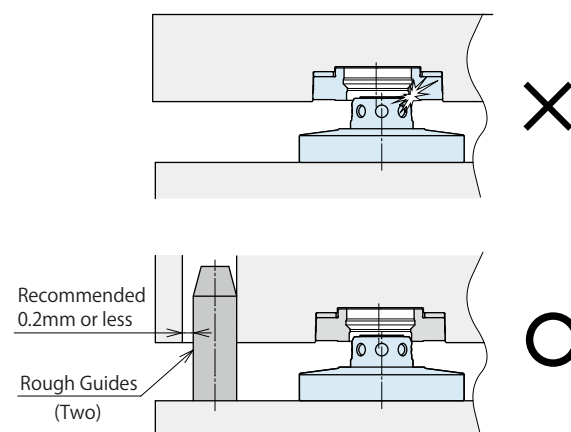

- A pallet must be level with a base plate during loading and unloading, otherwise clamps and blocks will be damaged. Provide guide pins (rough guides) to keep the pallet level during loading and unloading.

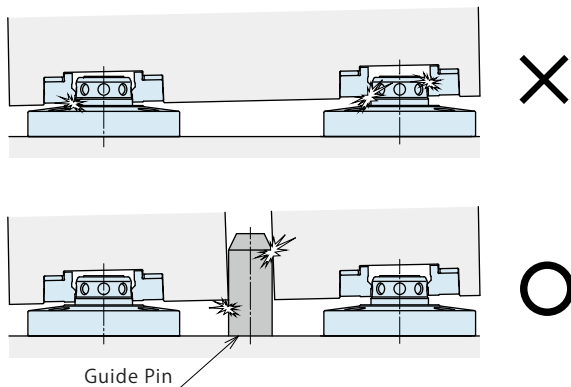

6) When using with Auto Coupler (JVC/JVD/JVE/JVF).

- WVG does not have a lifting function. When using with an auto coupler, make sure not to lift or tilt a pallet, and it becomes the allowable dimension shown on 3). Locking when the pallet is lifted or tilted, the clamp does not operate normally, causing damage on the clamp. Please prepare a tilting prevention. (Refer to the product catalog on our website for the reaction force caused by the internal spring of auto coupler.)

7) Clamp Action Confirmation When using Sensor Attachment (WVGT)

- WVGT is equipped with a built-in magnet that detects the clamping action by using with an auto switch.

Please select one depending on the environment.

Please use D-P3DWA (SMC) for an environment which generates a magnetic field disturbance.

Depending on an installation position of an auto switch, it can be projected out from the bottom of the sensor attachment.

Cautions

Installation Notes

- 1) Check the fluid to use.
 - Please supply filtered clean dry air.
 - Oil supply with a lubricator etc. is unnecessary.
- 2) Preparation for Piping
 - The pipeline, piping connector and fixture circuits should be cleaned and flushed thoroughly. The dust and cutting chips in the circuit may lead to fluid leakage and malfunction.
 - There is no filter provided with this product for prevention of contaminants in the air circuit.
- 3) Applying Sealing Tape
 - Wrap with tape 1 to 2 times following the screwing direction. Wrapping in the wrong direction will cause leaks and malfunction.
 - Pieces of the sealing tape can lead to air leaks and malfunction.
 - When piping, be careful that contaminant such as sealing tape does not enter in products.
- 4) Installation of the Product
 - When mounting the product use hexagonal socket bolts (with tensile strength of 12.9) and tighten them with the torque shown in the table below. Tighten them evenly to prevent twisting or jamming.

Clamp Model	Block Model	Mounting Bolt		Tightening Torque (N·m)
		Thread Size	Qty.	
WVG	WVGB	M4×0.7	4	3.2
WVG0040 WVG0060	WVGB040 WVGB060	M5×0.8	4	6.3
WVG0100	WVGB100	M6×1	4	10

- 5) Removal of the Product
 - Insert jack bolts and tighten them evenly to remove the product.
 - Protect the thread part with parallel pins, etc. as shown in the drawing below not to damage the surface of mounting bolts.

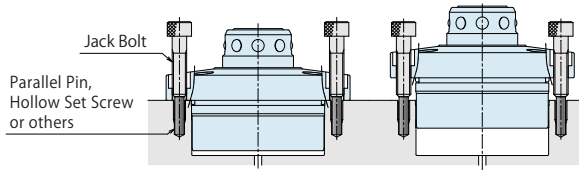

Level Adjustment of WVGB Block Seating Surface

(In case of Embedded Mounting)

- When mounting each block to the fixture plate, adjust the level of block seating surface as described below.
(Recommended Level Adjustment : within ± 0.01 mm)
- ① Install in order of the level adjustment collar and the block to the fixture and tighten them with the specified torque.
 - ② Measure the level of the seating surface of each block.
 - ③ In case the levels are not even, remove the blocks, and grind the level adjustment collar so that the level range is within ± 0.01 mm.
 - ④ Once again, install the block and level adjustment collar into the fixture plate, and check the levels.

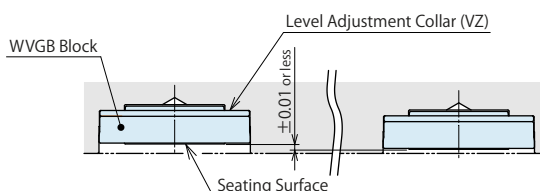

Notes on Handling

- 1) It should be operated by qualified personnel.
 - Hydraulic and/or pneumatic machines and devices should be operated and maintained by qualified personnel.
- 2) Do not operate or remove the product unless the safety protocols are ensured.
 - ① The machine and equipment can only be inspected or prepared when it is confirmed that the safety devices are in place.
 - ② Before removing the product, make sure that the above-mentioned safety devices are in place. Shut off the pressure and power source, and make sure no pressure exists in the air circuits.
 - ③ After stopping the product, do not remove until the temperature drops.
 - ④ Make sure there is no trouble/issue in the bolts and respective parts before restarting the machine or equipment.
- 3) Do not touch the clamp while it is working. Otherwise, your hands may be injured.

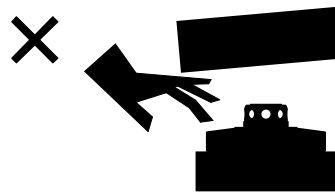

- 4) Do not disassemble or modify.
 - If the product is taken apart or modified, the warranty will be voided even within the warranty period.
- 5) Do not apply an impact on the product during loading/unloading.
 - Failure to do so leads to damage of the product and decrease in locating accuracy.

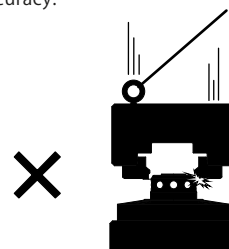

● Maintenance and Inspection

- 1) Removal of the Product and Shut-off of Pressure Source
 - Before removing the product, make sure that safety devices and preventive devices are in place. Shut off the pressure and power source, and make sure no pressure exists in air circuits.
 - Make sure there is no abnormality in the bolts and respective parts before restarting.
- 2) Regularly clean out each reference surface (locating surface and seating surface) of the locating products (WVG/WVGB).
 - WVG model can remove contaminants with cleaning function (air blow function). However, hardened cutting chips, adhesive coolant and others may not be removed. Make sure there are no contaminants before installing a workpiece/pallet.
 - Continuous use with contaminant on components will lead to locating accuracy failure, malfunction and air leakage.

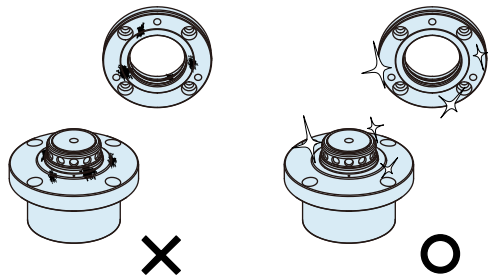

- 3) Regularly tighten pipes, mounting bolts and others to ensure proper use.
- 4) Make sure there is a smooth action without an irregular noise.
 - Especially when it is restarted after left unused for a long period, make sure it can be operated correctly.
- 5) The products should be stored in the cool and dark place without direct sunshine or moisture.
- 6) Please contact us for overhaul and repair.

● Warranty

- 1) Warranty Period
 - The product warranty period is 18 months from shipment from our factory or 12 months from initial use, whichever is earlier.
- 2) Warranty Scope
 - If the product is damaged or malfunctions during the warranty period due to faulty design, materials or workmanship, we will replace or repair the defective part at our expense. Defects or failures caused by the following are not covered.
 - ① If the stipulated maintenance and inspection are not carried out.
 - ② Failure caused by the use of the non-confirming state at the user's discretion.
 - ③ If it is used or handled in inappropriate way by the operator. (Including damage caused by the misconduct of the third party.)
 - ④ If the defect is caused by reasons other than our responsibility.
 - ⑤ If repair or modifications are carried out by anyone other than Kosmek, or without our approval and confirmation, it will void warranty.
 - ⑥ Other caused by natural disasters or calamities not attributable to our company.
 - ⑦ Parts or replacement expenses due to parts consumption and deterioration. (Such as rubber, plastic, seal material and some electric components.)

Damages excluding from direct result of a product defect shall be excluded from the warranty.



KOSMEK LTD.

▶ <http://www.kosmek.com/>

HEAD OFFICE 1-5, 2-chome, Murotani, Nishi-ku, Kobe-city, Hyogo, Japan 651-2241
TEL.+81-78-991-5162 FAX.+81-78-991-8787

United States of America SUBSIDIARY	KOSMEK (USA) LTD. 650 Springer Drive, Lombard, IL 60148 USA TEL. +1-630-620-7650 FAX. +1-630-620-9015
MEXICO REPRESENTATIVE OFFICE	KOSMEK USA Mexico Office Av. Santa Fe 103, Int. 59, col. Santa Fe Juriquilla, Queretaro, QRO, 76230, Mexico TEL. +52-1-55-3044-9983
EUROPE SUBSIDIARY	KOSMEK EUROPE GmbH Schleppeplatz 2 9020 Klagenfurt am Wörthersee Austria TEL. +43-463-287587 FAX. +43-463-287587-20
CHINA SUBSIDIARY	KOSMEK (CHINA) LTD. Room601, RIVERSIDE PYRAMID No.55, Lane21, Pusan Rd, Pudong Shanghai 200125, China TEL. +86-21-54253000
INDIA BRANCH OFFICE	KOSMEK LTD. - INDIA 4A/Old No:649, Ground Floor, 4th D cross, MM Layout, Kavalbyrasandra, RT Nagar, Bangalore -560032 India TEL.+91-9880561695
THAILAND REPRESENTATIVE OFFICE	KOSMEK Thailand Representation Office 67 Soi 58, RAMA 9 Rd., Phatthanakan, Suanluang, Bangkok 10250, Thailand TEL. +66-2-300-5132 FAX. +66-2-300-5133

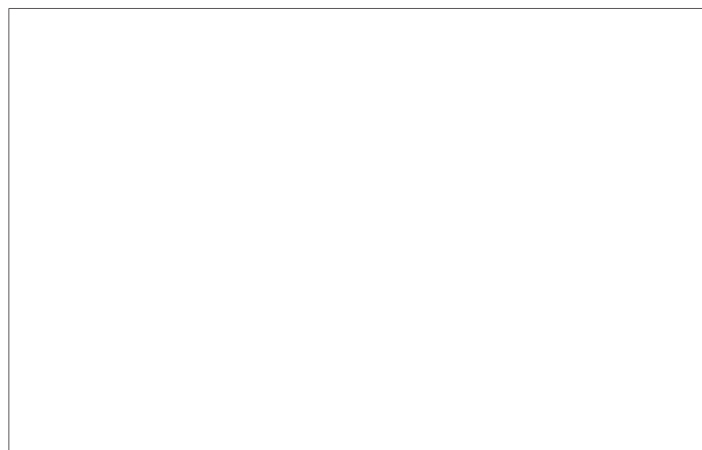

- For Further Information on Unlisted Specifications and Sizes, Please call us.
- Specifications in this Leaflet are Subject to Change without Notice.

